

Zero emissions in the production of hydrogen fuel using seawater as the main resource through the artificial leaf tool: a proposal for a bibliographic review

Karla Paola Paco Izarra^{a*}, Pamela Del Carmen Enriquez Villegas^a, Angie Kinverlin Inga Ramos^a and Dante Manuel García Jiménez^a

^aUniversidad Continental, Peru

CHRONICLE

Article history:

Received: November 20, 2022

Received in revised format:

December 28, 2022

Accepted: March 7, 2023

Available online:

March 7, 2023

Keywords:

Artificial leaf

Hydrogen

Production

Clean energy

Sea water

ABSTRACT

Polluted air creates health problems for people, plants and animals today due to many factors in industrial cities and power generation projects, transportation and chemical industry and others. It is for this reason that this research in bibliographic review allows us to know the different solutions to produce hydrogen through the analysis of the Scopus database and the VOSviewer tool that allows us to analyze the data, considering the variables that are artificial leaf, hydrogen, production, clean energy through seawater, graphs and tables were obtained which provide us with an analysis of the number of publications, the countries that carry out these investigations and the bibliometric maps worldwide for a global analysis. The results allow us to analyze and learn about the different solutions and materials that are used to carry out artificial photosynthesis that develops the production of hydrogen by separating water molecules with the aim of emitting zero emissions and being able to use it in different applications such as fuel, energy electrical, industrial uses and others. The purpose of this research is to allow us to make better decisions to apply this methodology according to the materials that we have in greater scope and that is a promising future for a generation of the new industry for the following years, also considering the objectives of sustainable development and finally, motivate readers to continue with these investigations and be able to apply it with institutions in charge of combating this problem.

© 2023 by the authors; licensee Growing Science, Canada.

1. Introduction

The problem caused by greenhouse gas emissions causes almost 99% of the entire world population to breathe polluted air and this air exceeds the unhealthy levels of fine particles in the air, due to industrialized cities and rapid globalization, generating cerebrovascular diseases and respiratory diseases, each year more than 7 million people die from these and other diseases (Trujillo et al., 2021), likewise 90% of people are exposed to respiratory diseases (Januszkiewicz & Kowalski, 2019), however air quality is already monitored in more than 117 countries (UN, 2023). 86% of petroleum derivatives such as gasoline, diesel, natural gas, and liquefied gas all generate CO₂ emissions (Abdelghany et al., 2022) in the United States at the transportation level gasoline and diesel were responsible for generating 34.2% of emissions, generating energy generated 32.9% of the emissions and the cement industry, iron, steel and production of chemical substances generated 15.4% (EPA, 2023) of greenhouse effect emissions and in Peru the capital Lima found particles of nitrogen dioxide NO₂ and sulfur dioxide SO₂ being harmful to health and which are found in different parts of the world according to (DIGESA, 2022). Hydrogen production in 96% is obtained in an industrialized way with the combustion of fossils in hydrocarbons, pyrolysis and methane (Ngoc, 2021) which generates greenhouse emissions currently the production of hydrogen through steam reforming of hydrocarbons emits 830 million tons of CO₂ per year (Grimm et al., 2022) and hydrogen would have to be produced at 520 million tons per year before 2050 in order to generate a neutral balance of CO₂ (Escamilla et al.,

* Corresponding author.

E-mail address: 71933893@continental.edu.pe (K. P. Paco Izarra)

2022). Since the 21st century, research has been carried out on strategies that allow us to improve the quality of life and the air we breathe, for this reason strategies are used that allow the reduction or elimination of carbon dioxide CO₂, reduce greenhouse gases (Arroyave, 2023) and this is how technology transforms these strategies into solutions such as the electrolysis of water with the help of renewable energy (Aldieri et al., 2022) sources allows obtaining hydrogen from seawater in an effective way (Escamilla et al., 2022) through the similarity of a process of photosynthesis and being able to use it as a fuel obtained through the sun that would resolve and reduce CO₂ pollution worldwide (Rahaman et al., 2020). Producing hydrogen through the solar division of water represents a potentially technological and ecological option for the future (Nguyen et al., 2022) therefore it will be used in different industries as fuel in air and land transport, as a material for the pharmaceutical industry and be transported to power generates energy to houses (Grimm et al., 2022). In order to propose a solution to solve environmental pollution and generate hydrogen that does not emit greenhouse emissions, a bibliographic analysis was carried out with the support of the VOSviewer tool, which allows a full-level analysis of the data obtained.

2. Materials and methods

The methodology carried out is a bibliographic review that provides a better quality in the analysis of more than 100 bibliographic references, the subject of this research is to provide a greater scope of the artificial leaf tool to produce water-based fuel without emitting pollution, that is, zero carbon emissions. For this, the scientific tool provided by Scopus was used.

Firstly, the results obtained from Scopus were used, which allows us to cover many investigations with respect to each variable animalizing with a scientific basis and a wide range of bibliographic references which gives consistency to better understand the analysis of this tool for the production of fuel without contaminating.

Second, the analysis of the data obtained with the VOSviewer software was carried out, which allows us to understand the words or cable variables visually with a minimum of 100 variables to analyze (van Eck & Waltman, 2010), in order to show the variables that are most mentioned in the investigations in a visual and easy to understand way. (Ding Ying et al., 2014). All this was obtained through the analysis of Scopus in formats (.csv) everything was analyzed until the year 2023 according to the following criteria:

- First, the Scopus data of the following variables "Hydrogen", "fuel" and "production" were obtained, identified from articles and international scientific journals that obtain clean energy, hydrogen production and among others, which was analyzed in different languages.
- Second, the Scopus data of the variable "Artificial Leaf" identified from articles and international scientific journals on clean energy, materials science and others was obtained and analyzed in different languages.
- Third, the Scopus data of the variable "Clean energy" and "Sea Water" identified from articles and international scientific journals on cleaner production, data science, energy reports and clean energy were obtained.

At the end of Fig. 1 and Fig. 6, Graphs 1-3 with the data obtained were obtained. This result allows us to analyze it using the VOSviewer tool, which provides us with the words with the greatest interaction and allows us to better analyze a large number of bibliographic reviews.

3. Results

3.1 Biometric analysis of hydrogen production as fuel

From the year 2001 to the year 2023, 537 documents were found related to the variables "Hydrogen", "fuel" and "production", in the table we can see that in the year 2022 a record of 100 documents with the keywords was obtained.

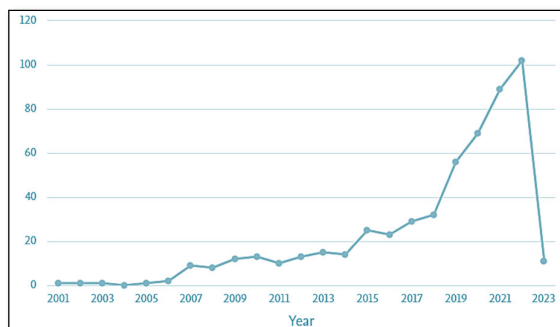

Fig. 1. The growth of the publication based on the variables "Hydrogen", "fuel" and "production"

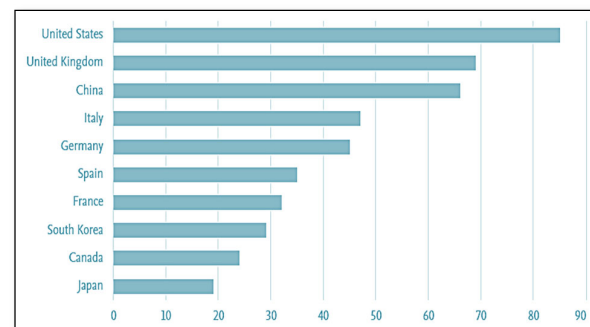
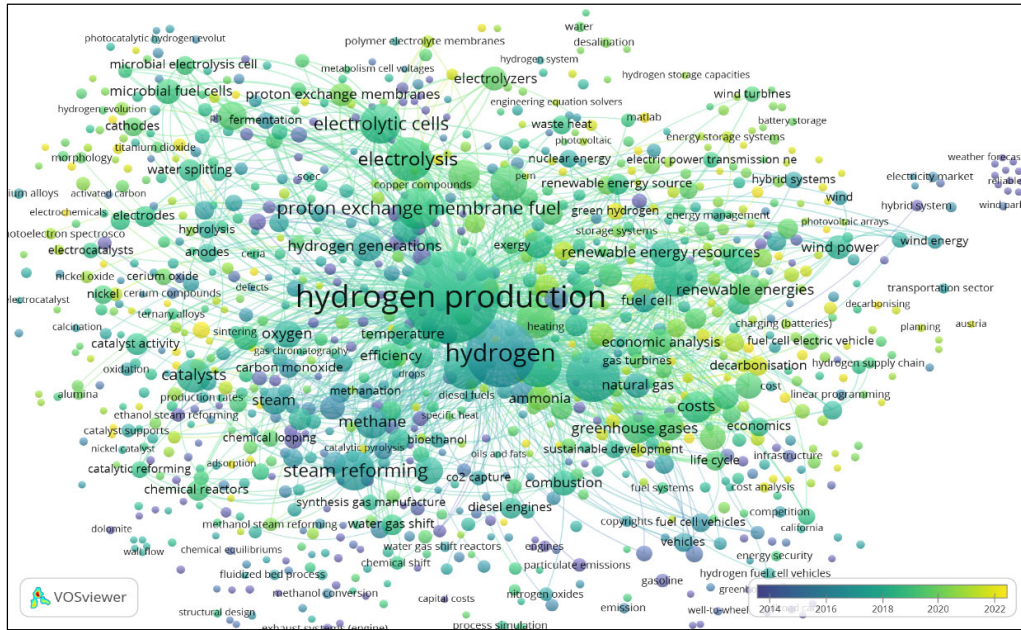

Fig. 2. Countries that published related to the words "Hydrogen", "fuel" and "production". Source: Scopus scientific review

Source: Scopus scientific review.

The most interested countries in producing hydrogen fuel are the United States, United Kingdom, China and Italy with more research of 50 scientific articles or more, as shown in Fig. 2. The database obtained from Scopus is analyzed using the VOSviewer software, where the interaction between the variables of each investigation are analyzed, which are: Hydrogen, fuel and production, which allows us to visualize in a concrete and effective way the most persistent words which are Hydrogen production, hydrogen and proton Exchange membrane fuel, in addition to this, the calorimetry is provided over time from 2014 to 2022 as shown in graph No. 1.



Graph. 1. Database map of the variables “Hydrogen”, “fuel” and “production”. with more interaction
Source: Obtained from VOSviewer

3.2 Biometric analysis of artificial leaf

From the year 2013 to the year 2022, 67 documents were found related to the variable "Artificial Leaf" in the table we can see that in 2015 a record of 12 documents with the keywords was obtained.

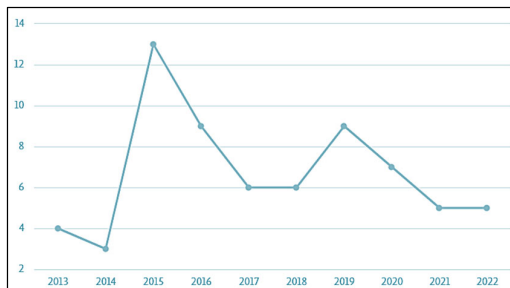

Fig. 3. The growth of the publication based on the variable "Artificial Leaf". Source: Scopus scientific review

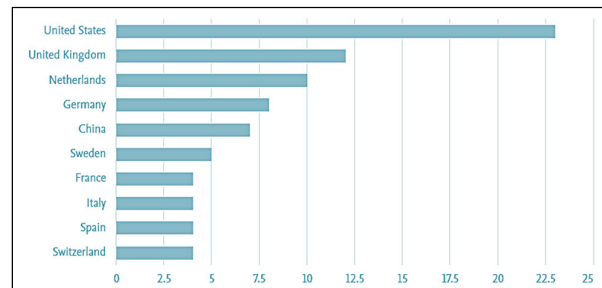

Fig. 4. Countries that published according to the relationships of the word "Artificial Leaf". Source: Scopus scientific review

The most interested countries in its properties and benefits of the artificial leaf are the United States, the United Kingdom, and the Netherlands with more research of 10 scientific articles or more, as shown in Fig. 4. The database obtained from Scopus is analyzed using the VOSviewer software, where the interaction between the variable “Artificial Leaf” is analyzed, which allows us to visualize in a concrete and effective way the most persistent words which are catalysts, hydrogen production, electrocatalysts and additional solar energy to this, calorimetry is provided over time from 2020 to 2022 as shown in graph No. 2.

The most interested countries in clean energy obtained from seawater are China, the United States, the United Kingdom, and China with more research of 60 scientific articles or more, as shown in Fig. 6. The database obtained from Scopus is analyzed using the VOSviewer software, where the interaction between the variables “Clean energy” and “Sea Water” is analyzed, which allows us to visualize in a concrete and effective way the most persistent words which are Carbon dioxide, seawater, renewable energies and desalination, in addition to this, the calorimetry is provided over time from 2020 to 2022 as shown in Graph 3.

3.4 Hydrogen Production

Hydrogen production for the year 2050 is projected to reach 12% of energy consumption worldwide, since it will generate benefits for the industrial sector, transport and energy conservation (Hassan et al., 2023), after analyzing all Renewable energy production solutions, as well as wind and photovoltaic solutions that generate clean energy, found that their costs are high and increase over time, which is why hydrogen fuel is a healthy, profitable and viable option (Afif et al., 2022) and meets the sustainable development goals, which is decarbonization (Hassan et al., 2023).

The pharmaceutical industry consumes 45 million tons of hydrogen to produce methanol and ammonia in oil refineries that consume 40 million tons, therefore the production of hydrogen that does not generate pollutants is the priority (Jaradat et al., 2022), Today the generation of hydrogen is carried out by renewing renewable energy and water, which goes through electrolysis to obtain hydrogen, after which it is to be compressed in tanks and transported in different elements and, after that, to be used, as it is observed in Graph 4.

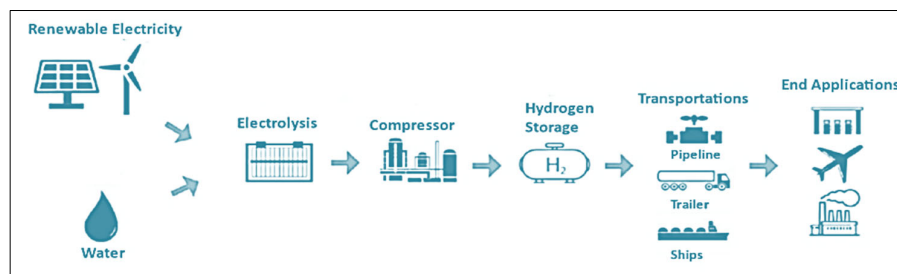

Graph. 4. The hydrogen supply chain. Note. The graph shows the entire logistics process from production to its final use of hydrogen. Taken from Potential of producing Green hydrogen in Jordan Energies, by Jaradat et al., 2022.

Producing ecological hydrogen is 2 to 3 times more expensive than producing gray hydrogen using fossil fuels, however, this hydrogen will not emit greenhouse gas emissions (Bednarczyk et al., 2022), therefore the production of hydrogen using water generates investment in fixed assets, energy expenditure, production and operating expenses (Hassan et al., 2023).

There are several methodologies for obtaining contaminant-free hydrogen such as electrolysis of water, biomass gasification, coal, water with the support of technologies (Burchart et al., 2022), also catalysts together with water as a donor of electrons that allows generating hydrogen (Rahaman et al., 2020), however these technologies have to evaluate the geographical distribution, resource availability, speed of time and hours of sunshine in the year (Jaradat et al., 2022).

The future of energy conservation and storage must be considered by evaluating both production and distribution and storage prices (Scheepers et al., 2023) since a problem to be solved is hydrogen storage (Ngoc, 2021) for this reason see profitable storage pathways since energy is lost in the storage, production and distribution process (Escamilla et al., 2022), as well as the Nanoogrid for home applications that aims to manage different technologies for future generations and storage systems (Lorenzo et al., 2022), there are also photocatalytic lignocellulosic hydrogen evolution and storage systems that capture CO₂ from the air, with electrosynthesis systems (Sadhukhan et al., 2022), therefore consider small hydrogen production plants near of the consumer will allow us to reduce losses of hydrogen in transport and storage (Escamilla et al., 2022).

There are materials such as catalysts that generate abundant hydrogen on planet earth such as bimetallic sulfide, cobalt, molybdenum sulfide or cobalt tungsten, these are free of noble metals in oxygen evolution (Nguyen et al., 2022; Bucci et al., 2021), likewise the perovskite tandem as the function of producing solar thermal hydrogen (Orfila et al., 2022) and giving higher efficiency and selectivity for solar CO at bias-free conditions (Rahaman et al., 2020).

3.5 Artificial Leaf

The artificial leaf is a powerful technology as it has the property of generating hydrogen by absorbing the sun which achieves water splitting by a photo-electrochemical cell (Nguyen et al., 2022), the triple junction amorphous silicon solar cell (3jn - a-Si) is represented in graphs No. , where this solar junction structure with pins are separated from tunnel junctions and covered by a transparent ITO and deposited on a reflective metal with a zinc oxide metal layer (ZnO) and supported by a stainless steel substrate (Shao et al., 2019)

Materials: P : nc – Si = transparent doped layer envelope, N : a – Si = transparent doped layer envelope that are so thin that they do not allow the components to unite but facilitate the passage of electrons; Zinc oxide (ZnO), Stainless steel substrate and Ito: top layer the union results in a moisture resistant, super thin and solid material

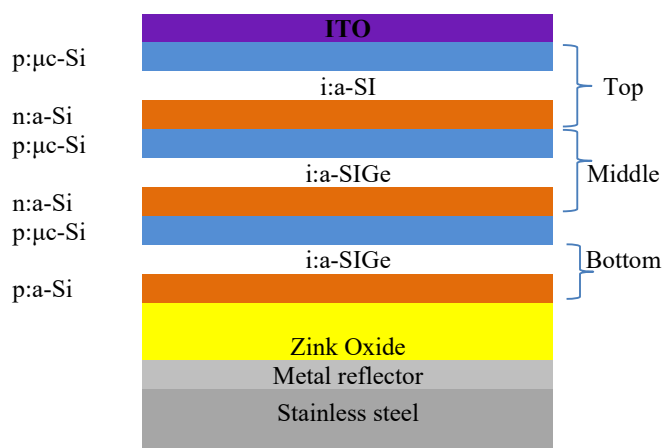

Graph 5. Triple junction amorphous silicon solar cell (3jn-a-Si). Note. The graph shows the union of all the materials to form the silicic cell. Taken from Photocatalytic water splitting cycle in a dye-catalyst supramolecular complex: Ab initio molecular dynamics simulations, by Shao et al, 2019.

The steps to produce this cell are as follows: first a stainless steel base and second AG/ZnO and later 3jn-a-Si, for this it was first covered with a thermal tape 1, for the anodic work; second was covered with a thermal tape 2, to cover all areas third was covered with a swab containing 1M HCl and recorded; fourth cleaning of stainless steel; fifth, tape 2 was removed, cleaned and the thermal tape 3 was put on, sixth, the missing layers of thermal tape were covered, seventh it was covered with conventional acrylic paint and finally tape 1 and 5 were removed, then washed, to be used, tape 3 and 4 will be removed to make electrochemical photo.

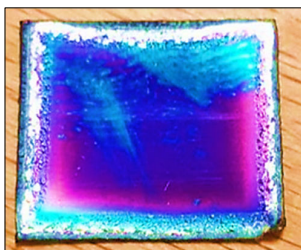

Graph. 6. Triple junction amorphous silicon solar cell (3jn-a-Si). Note. Real image of the silicon cell. Taken from Photocatalytic water splitting cycle in a dye-catalyst supramolecular complex: Ab initio molecular dynamics simulations, by Shao et al., 2019.

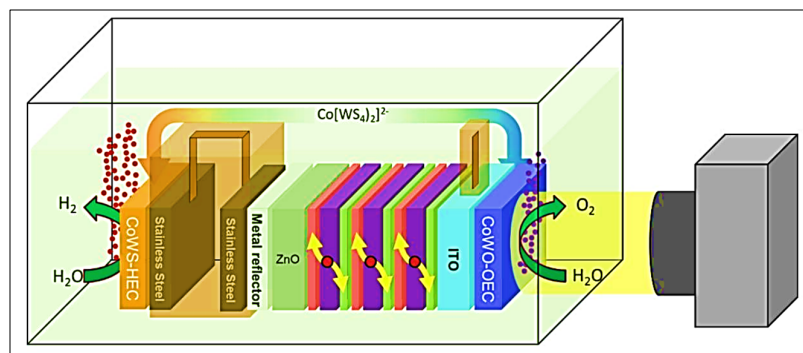

Graph. 7. The amorphous silicon cell reinforced with dual catalysts. Note. the assembly of the catalysts to obtain better results. Taken from Photocatalytic water splitting cycle in a dye-catalyst supramolecular complex: Ab initio molecular dynamics simulations, by Shao et al., 2019.

The artificial triple junction sheet of silicon reinforced with (Co(WS₄)₂)₂- an electrolyte solution to drive triple junction photodeposition, with three absorption pins effectively, the bottom with the electrons and the top with the junction holes

they were able to get to the solid electrolyte to oxidize and reduce the water. The $(\text{Co}(\text{WS}_4)_2)_2$ is formed with the dual catalysts CoWO and CoWS to totally split water, thus obtaining an artificial leaf capable of splitting water by the sun without extra help. CoWS-HEC amorphous cobalt tungstene oxide with phosphate attached to the surface that function as catalysts (Nguyen et al., 2022). The greater the irradiation of light, the better results, but there are always instability failures of the silicon semiconductor nucleus due to the exposure of the electrolyte (Melder et al., 2019), the design of the catalysts are with large amounts of holes, the semiconductor interface, cocatalyst and electrolyte that involve accumulate, transfer, and combine charge inputs (Xu et al., 2019).

There is another methodology to produce hydrogen is through the generation of photovoltage and photocurrent in a solid-state PEC cell that works with humidified air and that improves when it is in contact with the Pt cathode with a photocathode that is eliminated with the photoanode (Ngoc, 2021), the humid gas is obtained from the water supply, which has the polymer electrolyte as interface, likewise sunlight as an energy source and water as an electron source allows photoelectrocatalysis and when combined with the PEC cell (photoelectrochemical) allows to produce fuel from CO_2 using sunlight (Rahaman et al., 2020)

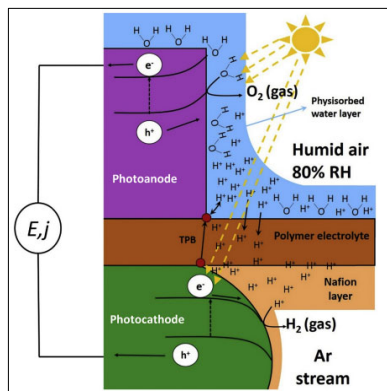

Graph. 8. The PEC cell. Note. It works with humidified air and radiation from the sun. Taken from Engineering of a viable artificial leaf for solar fuel generation. Grenoble Alpes University, by Ngoc, 2021.

Splitting water vapor and producing hydrogen in a tandem cell contributes to proton transport to the nafion, represented by the brown area on the photocathode, this is replaced by pt nanoparticles which are catalysts for proton reduction and evolution of hydrogen, is achieved thanks to in the gas phase the electrolyte, the cathode and the protons unite with the electrons and hydrogen gas is produced thanks to the pores of the cathode electrode and the flow of hydrogen Ar (Ngoc, 2021), there are abundant non-toxic catalysts on earth is a promising path for efficient and durable solar energy storage and conversion systems (Melder et al., 2019).

There is another tool such as carbon fiber paper coated by magnesium oxide (MnOx/CFP) prepared by means of a redox. This is promising for the catalysis of oxidation of electrochemical water and abundant in the earth, since it can be applied in alkaline, neutral electrolytes. and even acids (Melder et al., 2019), likewise also the metal magnesium that is economically accessible and non-toxic evolved into $\text{Mn}_4\text{CaO}_5(\text{H}_2\text{O})$, which oxidizes abundant water in x-rays in neutral media, likewise asserts that it is favored in alkaline waters for reasons not yet studied.

Photoanated perovskite (BiVO_5) assembled with cathode (Cu_9In_4) to form an artificial sheet are emerging light absorbers for solar fuel production by joining with a polarized cathode that has the property of oxidizing water. It has the unique dendritic foam morphology design and a hole transport layer was incorporated (Rahaman et al., 2020)

A $\text{ZnSePbS}/\text{Au}/\text{TiO}_2$ heterojunction photocatalyst prepared at 120°C had the best efficiency in obtaining hydrogen and the metal as a reagent in a 20% by weight solution of water, producing 5011 mmol g of hydrogen, the architecture of the PEC (photoelectrochemical) device serves to separate the electron-hole, with band bending, obtaining a local imbalance of charge neutrality, being responsible for the charge transfer to a device, this catalytic charge becomes an approach to eliminate losses to a heterogeneous system for an efficient design of the photo anode and this is how energy is obtained through the sun with the division of the photocatalyst $\text{ZnSePbS}/\text{Au}/\text{TiO}_2$ managed to produce hydrogen (Liu et al., 2021)

3.6 Clean energy

Hydrogen is a power to be able to decarbonize the environment, which is a solution to meet the objective of sustainable development (Cooper et al., 2022) in order to reduce greenhouse gas emissions, hydrogen is a strong option to maintain current and future energy systems since they are currently consumed in chemical, refining and other industries; however, the future of this industry will allow reaching more industries, generating a positive effect on the environment (Qazi, 2022), so invest in innovative solutions using the digitization and implementation of objectives based on increasing production to obtain energy from hydrogen free of greenhouse effect emissions (Borowski, 2022), which evolves over time and is

improved with the aim of reducing costs and being able to generate in large amount to meet needs and better energy security (Qazi, 2022).

Hydrogen is marketed as natural gas, it generates a great environmental impact because it does not generate pollutants in its production, however the impact that would take a future level to measure the losses and emissions of each stage of the supply chain and the global warming impacts that this causes (Cooper et al., 2022), likewise in European cities it is still difficult to adapt to renewable energies as a use policy, since it generates extra investment costs. (Panarello & Gatto, 2023)

When hydrogen is stored, transported and loaded, quantities of hydrogen are lost, which is why the tanker tank is considered a storage and transfer tool (Cooper et al., 2022) and storing it at sea is more profitable due to a budget of carbon and a high CO₂ tax in the country of Norway, where they work with the objective of exporting clean energy in the future (Zhang et al., 2022), this is how places with better economies will allow themselves to use and adapt to renewable energies (Panarello & Gatto, 2023), all this because electricity and gas consumption in countries such as the European Union could increase up to 1.4 trillion euros, compared to 200 billion euros in recent years (Borowski, 2022).

4. Discussion

Analyzing these investigations allows us to know the different solutions that are available thanks to an in-depth and concise bibliographic review analysis on obtaining hydrogen through the artificial leaf, using seawater as a resource with the aim of making it a clean energy and after This can be used as fuel for different applications considering the environmental impact since it does not generate greenhouse gas emissions to the environment. The analysis was carried out using the VOSviewer tool of the variables “Hydrogen”, “production”, “Artificial Leaf”, “Clean energy” and “Sea Water”, which has a higher frequency of publications in countries such as the United States, United Kingdom and China. , likewise rescuing that at the Peruvian level there is no document related to these variables analyzed, this puts us at a disadvantage and lack of interest compared to other countries, professionals from other continents and organizations in charge of improving and ensuring air quality. There are renewable solutions that allow mitigating carbon dioxide (CO₂) emissions, however there is a large sector such as heavy industry, cement manufacturing and chemical or petroleum products that represent 20% of global carbon dioxide emissions. (CO₂), the steel industry emits 5% of CO₂ emissions worldwide (Afif et al., 2022), for this reason the hydrogen obtained from the artificial leaf using seawater is a solution that would allow generating great benefits for the health of the environment, for this reason political support is required since the entities are the main responsible for improving the quality of energy, therefore countries such as the European Union are planning and presenting national strategies for the production of hydrogen, Likewise, for hydrogen at the local level, it needs not only from the authorities but also investment, private capital, infrastructure, economic and technical (Hassan et al., 2023).

For these problems, the application of the sustainable and promising future is due to energy sources, since there is abundant raw material in easily stored fuel, the oxidation of oxygen water (OER), is essential to obtain solar fuels such as hydrogen (Bucchi et al., 2021) For this reason, this storable energy is a future solution to obtain clean energy, inspired by natural photosynthesis and the photocatalytic water, thus achieving an artificial photosynthesis system, the infrared radiation of the sun generates a large number of photons around of 50% of the solar spectrum (Liu et al., 2021), likewise photoelectrochemical cells allow us to use a solar cell to feed a water electrolysis system in a wiring (Nguyen et al., 2022), thus photoelectrochemical hydrogen (PEC) with the help of solar radiation through solar photons passes through the semiconductor and the use of electrocatalysts, managing to divide the water a in hydrogen and oxygen (Grimm et al., 2020).

Conventional alkaline electrolysis and PEN technology work with hydroxide ions and hydrogen protons, the use with bifunctional electrodes, considering the reactions of the OER and HER catalysts to study their reactions in the artificial leaf (Falcao, 2023) in order to generate energy with selective and efficient catalysts (Rahaman et al., 2020), by producing this hydrogen it can be stored and converted into electrical energy through fuel cells and carbon-free (De Lorenzo et al., 2022) for its application in the project of the In the Red Sea, a photovoltaic system and electrical network were used to produce hydrogen, where they were successful in a period of 11 years in the recovery of capital, in addition they will be able to reduce 3042 tons of CO₂ per year and a saving of USD 120,135 (Jaradat et al., 2022)

These different solutions shown in this analysis must be studied and applied according to the availability of the materials that you have and their functionality, since producing hydrogen is the least short and medium term to decarbonize transportation, it creates a new chain of value for the energy sector (Sanjivy et al., 2023), which is why it is increasingly potential, with the benefits of decarbonization, likewise in Russia it is seeing it as a new large-scale economy in the export of clean hydrogen fuels (Potashnikov et al., 2022), also oil and gas companies saw the option of using the technology to produce blue hydrogen as a profitable option, however they consider that it should be forecast to produce 400 million tons of Blue H₂ in 30 years a challenge because there is still no significant demand (Sanjivy et al., 2023) but it has a promising future since in an applied survey it was observed that according to At the educational level, responses were seen about the use of renewable energies such as hydrogen (Maciaszczyk et al., 2022) seeing an option to apply it.

5. Conclusión

The interpretation of this bibliographical research allows decisions to be made and solutions to hydrogen production to be seen. The results obtained allowed us to understand and analyze the solutions with different types of materials to produce an artificial leaf that can be found and differed according to availability. of materials and resources, there are different solutions and methodologies to obtain contaminant-free hydrogen such as water electrolysis, biomass gasification, coal, water with the support of technologies, likewise the triple-junction amorphous silicon solar cell (3jn-a-Si), also (Co (WS₄)₂) 2- reinforced triple junction silicon artificial sheet, magnesium oxide (MnOx/CFP) coated carbon fiber paper, perovskite photoanlated (BiVO₅) assembled with cathode (Cu₉₆In₄) to form an artificial sheet, a ZnSePbS/ Au /TiO₂ heterojunction photocatalyst prepared at 120 °C, all these options are free. thanks to the analysis that could be collected through the bibliographic review in Scopus. At this time, we need to take action on the matter due to the great problems and diseases caused by air pollution and that will also be affected in the economy by taxes generated by the large amount of toxic emissions into the air. We conclude that we have different ways to solve the production of clean hydrogen and which we can apply to different systems such as energy, fuel and application in different industries for its application.

References

- Abdelghany, M., Shehzad, M., Mariani, V., Liuzza, D. & Glielmo, L. (2022). Two-stage model predictive control for a hydrogen-based storage system paired to a wind farm towards green hydrogen production for fuel cell electric vehicles. *International Journal of Hydrogen Energy*, 47(75), 32202–32222. <https://doi.org/10.1016/j.ijhydene.2022.07.136>
- Afif, M., Afif, A., Apostoleris, H., Gandhi, K., Dadlani, A., Ghaferi, A., Torgersen, J. & Chiesa, M. (2022). Ultra-cheap renewable energy as an enabling technology for deep industrial decarbonization via capture and utilization of process CO₂ emissions. *Energies*, 15(14), 5181. <https://doi.org/10.3390/en15145181>
- Agencia de protección ambiental de los estados unidos EPA, (13 de febrero, 2023). Emisiones de dióxido de carbono. <https://espanol.epa.gov/la-energia-y-el-medioambiente/emisiones-de-dioxido-de-carbono>
- Aldieri, L., Gatto, A., & Vinci, C. (2022). Is there any room for renewable energy innovation in developing and transition economies? Data envelopment analysis of energy behaviour and resilience data. *Resources, Conservation, and Recycling*, 186(106587), 106587. <https://doi.org/10.1016/j.resconrec.2022.106587>
- Arroyave Oyola, J. G. (2023). Factibilidad de una empresa de instalación de sistemas de adición de hidrógeno para la combustión en motores estacionarios y comercialización de reducción de emisiones.
- Bednarczyk, J., Brzozowska-Rup, K., & Luściński, S. (2022). Opportunities and limitations of hydrogen energy in Poland against the background of the European Union energy policy. *Energies*, 15(15), 5503. <https://doi.org/10.3390/en15155503>
- Borowski, P. (2022). Mitigating Climate Change and the Development of Green Energy versus a Return to Fossil Fuels Due to the Energy Crisis in 2022. *Energies*, 15. <https://doi.org/10.3390/en15249289>
- Bucci, A., García-Tecedor, M., Corby, S., Rao, R., Martin-Diaconescu, V., Oropeza, F., & Lloret-Fillol, J. (2021). Self-supported ultra-active NiO-based electrocatalysts for the oxygen evolution reaction by solution combustion. *Journal of Materials Chemistry A*, 9(21), 12700–12710.
- Burchart, D., Gazda-Grzywacz, M., Grzywacz, P., Burmistrz, P., & Zarebska, K. (2022). Life cycle assessment of hydrogen production from coal gasification as an alternative transport fuel. *Energies*, 16(1), 383. <https://doi.org/10.3390/en16010383>
- Cooper, J., Dubey, L., Bakkaloglu, S., & Hawkes, A. (2022). Hydrogen emissions from the hydrogen value chain-emissions profile and impact to global warming. *The Science of the Total Environment*, 830(154624), 154624. <https://doi.org/10.1016/j.scitotenv.2022.154624>
- De Lorenzo, G., Agostino, R. G., & Fragiaco, P. (2022). Dynamic electric simulation model of a Proton Exchange Membrane electrolyzer system for hydrogen production. *Energies*, 15(17), 6437. <https://doi.org/10.3390/en15176437>
- Dirección General de Salud Ambiental e Inocuidad Alimentaria, (23 de noviembre, 2022). DIGESA realiza estudio con la Municipalidad Metropolitana de Lima para la validación de metodología de muestreo de aire. <http://www.digesa.minsa.gob.pe/noticias/Setiembre2020/nota49.asp>
- Escamilla, A., Sánchez, D., & García-Rodríguez, L. (2022). Assessment of power-to-power renewable energy storage based on the smart integration of hydrogen and micro gas turbine technologies. *International Journal of Hydrogen Energy*, 47(40), 17505–17525. <https://doi.org/10.1016/j.ijhydene.2022.03.238>
- Falcão, D. (2023). Green Hydrogen Production by Anion Exchange Membrane Water Electrolysis: Status and Future Perspectives. *Energies*, 16, 943. <https://doi.org/10.3390/en16020943>
- Grimm, A., de Jong, W., & Kramer, G. (2020). Renewable hydrogen production: A techno-economic comparison of photoelectrochemical cells and photovoltaic-electrolysis. *International Journal of Hydrogen Energy*, 45(43), 22545–22555. <https://doi.org/10.1016/j.ijhydene.2020.06.092>
- Grimm, A., Sainte-Marie, A., Kramer, G., & Gazzani, M. (2022). Modeling photovoltaic-electrochemical water splitting devices for the production of hydrogen under real working conditions. *International Journal of Hydrogen Energy*, 47(23), 11764–11777. <https://doi.org/10.1016/j.ijhydene.2022.01.223>
- Hassan, Q., Abdulrahman, I. S., Salman, H., Olapade, O., & Jaszczur, M. (2023). Techno-economic assessment of green hydrogen production by an off-grid photovoltaic energy system. *Energies*, 16(2), 744.

- <https://doi.org/10.3390/en16020744>
- Januszkiewicz, K., Kowalski. (2019). Air purification in highly-urbanized areas with the use of TiO₂ New approach in designing urban public space with beneficial human condition. *IOP Conference Series: Materials Science and Engineering*, 603(032100). DOI:10.1088/1757-899X/603/3/032100
- Jaradat, M., Alstary, O., Juaidi, A., Albatayneh, A., Alzoubi, A., & Gorjian, S. (2022). Potential of producing green hydrogen in Jordan. *Energies*, 15(23), 9039. <https://doi.org/10.3390/en15239039>
- Liu, R., Fang, S., Dong, C., Tsai, K., & Yang, W. (2021). Enhancing hydrogen evolution of water splitting under solar spectra using Au/TiO₂ heterojunction photocatalysts. *International Journal of Hydrogen Energy*, 46(56), 28462–28473. <https://doi.org/10.1016/j.ijhydene.2021.06.093>
- Maciaszczyk, M., Czechowska-Kosacka, A., Rzepka, A., Lipecki, T., Łazuka, E., & Właż, P. (2022). Consumer awareness of renewable energy sources: The case of Poland. *Energies*, 15(22), 8395. <https://doi.org/10.3390/en15228395>
- Melder, J., Mebs, S., Heizmann, P. A., Lang, R., Dau, H., & Kurz, P. (2019). Carbon fibre paper coated by a layered manganese oxide: a nano-structured electrocatalyst for water-oxidation with high activity over a very wide pH range. *Journal of materials chemistry*, 7, 25333-25346.
- Ngoc, D. (2021). Engineering of a viable artificial leaf for solar fuel generation. Université Grenoble Alpes. Institut Polytechnique (Hanoi).
- Nguyen, D., Fadel, M., Chenevier, P., Artero, V., & Tran, P. (2022). Water-Splitting Artificial Leaf Based on a Triple-Junction Silicon Solar Cell: One-Step Fabrication through Photoinduced Deposition of Catalysts and Electrochemical Operando Monitoring. *Journal of the American Chemical Society*, 144(22), 9651-9660.
- Orfila, M., Linares, M., Pérez, A., Barras-García, I., Molina, R., Marugán, J., Botas, J., & Sanz, R. (2022). Experimental evaluation and energy analysis of a two-step water splitting thermochemical cycle for solar hydrogen production based on La_{0.8}Sr_{0.2}CoO_{3-δ} perovskite. *International Journal of Hydrogen Energy*, 47(97), 41209–41222. <https://doi.org/10.1016/j.ijhydene.2022.03.077>
- Organización de las naciones unidas (ONU). (2023). El 99% de la población respira aire contaminado. <https://news.un.org/es/story/2022/04/1506592>
- Panarello, D., & Gatto, A. (2023). Decarbonising Europe – EU citizens’ perception of renewable energy transition amidst the European Green Deal. *Energy Policy*, 172(113272), 113272. <https://doi.org/10.1016/j.enpol.2022.113272>
- Potashnikov, V., Golub, A., Brody, M., & Lugovoy, O. (2022). Decarbonizing Russia: Leapfrogging from fossil fuel to hydrogen. *Energies*, 15(3), 683. <https://doi.org/10.3390/en15030683>
- Qazi, U. (2022). Future of Hydrogen as an Alternative Fuel for Next-Generation Industrial Applications, Challenges and Expected Opportunities. *Energies*, 15, 4741. <https://doi.org/10.3390/en15134741>
- Rahaman, M., Andrei, V., Pornrunroj, C., Wright, D., Baumberg, J., & Reisner, E. (2020). Selective CO production from aqueous CO₂ using a Cu₉₆In₄ catalyst and its integration into a bias-free solar perovskite–BiVO₄ tandem device. *Energy & Environmental Science*. <https://doi.org/10.1039/d0ee01279c>
- Sadhukhan, J., Pollet, B., & Seaman, M. (2022). Hydrogen production and storage: Analysing integration of photoelectrolysis, electron harvesting lignocellulose, and atmospheric carbon dioxide-fixing biosynthesis. *Energies*, 15(15), 5486. <https://doi.org/10.3390/en15155486>
- Sanjivvy, K., Marc, O., Davies, N., & Lucas, F. (2023). Energy performance assessment of Sea Water Air Conditioning (SWAC) as a solution toward net zero carbon emissions: A case study in French Polynesia. *Energy Reports*, 9, 437–446. <https://doi.org/10.1016/j.egy.2022.11.201>
- Scheepers, F., Stähler, M., Stähler, A., Müller, M., & Lehnert, W. (2023). Cost-optimized design point and operating strategy of polymer electrolyte membrane electrolyzers. *International Journal of Hydrogen Energy*. <https://doi.org/10.1016/j.ijhydene.2022.11.288>
- Shao, Y., de Ruiter, J., de Groot, H., & Buda, F. (2019). Photocatalytic water splitting cycle in a dye-catalyst supramolecular complex: Ab initio molecular dynamics simulations. *The Journal of Physical Chemistry. C, Nanomaterials and Interfaces*, 123(35), 21403–21414. <https://doi.org/10.1021/acs.jpcc.9b06401>
- Trujillo, M., Alcántar, B., Ramírez, R., & López, A. (2021). Influence of aging on the physicochemical behavior of photocatalytic asphalt cements subjected to the natural environment. *Construction and Building Materials*, 295(123597). DOI:10.1016/j.conbuildmat.2021.123597
- Xu, K., Chatzidakis, A., Vøllestad, E., Ruan, Q., Tang, J., & Norby, T. (2019). Hydrogen from wet air and sunlight in a tandem photoelectrochemical cell. *International Journal of Hydrogen Energy*, 44(2), 587–593. <https://doi.org/10.1016/j.ijhydene.2018.11.030>
- Zhang, H., Tomaszgard, A., Knudsen, B., Svendsen, H., Bakker, S., & Grossmann, I. (2022). Modelling and analysis of offshore energy hubs. *Energy (Oxford, England)*, 261(125219), 125219. <https://doi.org/10.1016/j.energy.2022.125219>

