

**A study on the effect of thickness and spherical diagonal for LYP Infill Plate of shear walls****Mohammad Mohammadiasl<sup>a</sup>, Amir Baghban<sup>b</sup>, Peyman Beiranvand<sup>c\*</sup> and Hamidreza Babaali<sup>d</sup>**<sup>a</sup>PhD, Department of Civil Engineering, Khorramabad Branch, Islamic Azad University, Khorramabad, Iran<sup>b</sup>Assistant Professor, Department of Civil Engineering, University of Gonabad, Gonabad, Iran<sup>c</sup>Lecturer, Department of Civil Engineering, Lorestan University, Khorramabad, Iran<sup>d</sup>Assistant Professor, Department of Civil Engineering, Khorramabad Branch, Islamic Azad University, Khorramabad, Iran**ARTICLE INFO***Article history:*

Received 2 October 2022

Accepted 5 November 2022

Available online

5 November 2022

*Keywords:*

Steel shear wall

LYP

Thickness

Spherical diagonal

**ABSTRACT**

One of the most significant parameters which should be considered by all engineers is improving structures' strength subjected to lateral load. Steel shear wall whose duty is to affect lateral load (wind and earthquake) is a wall which consists of shear part. Application of low yield point (LYP) steel in shear walls allows the employment of moderate and/or stocky infill plates with low yielding and high buckling capacities, which can result in enhanced buckling stability, serviceability, and energy dissipation capacity of such systems. Infill LYP plate is used to improve shear wall behavior which leads to enhancement of stiffness. In the present research, infill plate with spherical appendages is applied, and its impact on plate stiffness, cyclic behavior and energy absorption are investigated. The spherical diameter has been chosen respectively 10 and 20 cm distributed with two patterns (diagonal and plus form). The best performance is for a LYP plate with a 10 cm spherical diagonal pattern.

© 2023 Growing Science Ltd. All rights reserved.

**1. Introduction**

A new material of steel, Low-Yield-Point Steel (LYP steel) has been invented and used in diverse lateral load conditions, LYP has low yield strength, high stiffness and high capacity. The maximum yielding stress of LYP is roughly 100 MPa which is  $\frac{1}{4}$  of conventional steel plate (ASTM A572-Gr. 50 steel) (Nassernia & Showkati, 2017; Lv et al. 2019; Wang et al. 2017). LYP is widely used because of having good ductility and strength in construction and different research (Zirakian & Zhang, 2015; Raisszadeh et al., 2018). For instance, they used LYP in the steel shear wall; the results showed that applying this steel can increase absorption energy to 63 % and reduce lateral displacement about 16% (Jebelli & Mofid, 2014). SPSW is studied and the effect of rigid and semi-rigid connection joints on behavior of SPSW was considered. The result of this study shows that using stiffeners increases yielding load up to 20 %. Also, using stiffeners in diagonal raises load bearing capacity about 5% in comparison with cross stiffeners in plastic state (Guo et al., 2015). Shahi and Adibrad (2017) used FEM (finite element method) and laboratory test to analyze behavior of LYP under cyclic and uniform load. Zirakian and Zhang (2015) studied LYP shear wall and addressed this fact although LYP has lower yielding stress than ordinary steel; however, it has better post buckling behavior compared to conventional steel. Ultimately, FEM and laboratory tests were used for analyzing the post buckling behavior of shear steel wall and escalation response of LYP steel under different load patterns (Zirakian & Zhang, 2015). Wang et al. (2017) reviewed LYP as shear steel and considered isotropic and kinematic hardening in this material and evaluated the cyclic behavior. Studied the LYP behavior under monotonic load and the ratio of  $W$  (wide) /  $t$  (thickness) in this shear wall, and this ratio is a variable and its influence has been investigated (Chen & Jhang, 2011). Some other researchers such as, (Mistakidis, 2010; Vigh et al., 2014; Boyajian & Zirakian, 2016) studied LYP plate because of its yield strength and high ductility. According to the presented research, using LYP enhances the strength behavior, stiffness, load capacity and performance compared to typical shear wall, so the aim of this study is to analyze the behavior of steel shear

\* Corresponding author.

E-mail addresses: [Peyman51471366@gmail.com](mailto:Peyman51471366@gmail.com) (P. Beiranvand)

ISSN 2291-8752 (Online) - ISSN 2291-8744 (Print)

© 2023 Growing Science Ltd. All rights reserved.

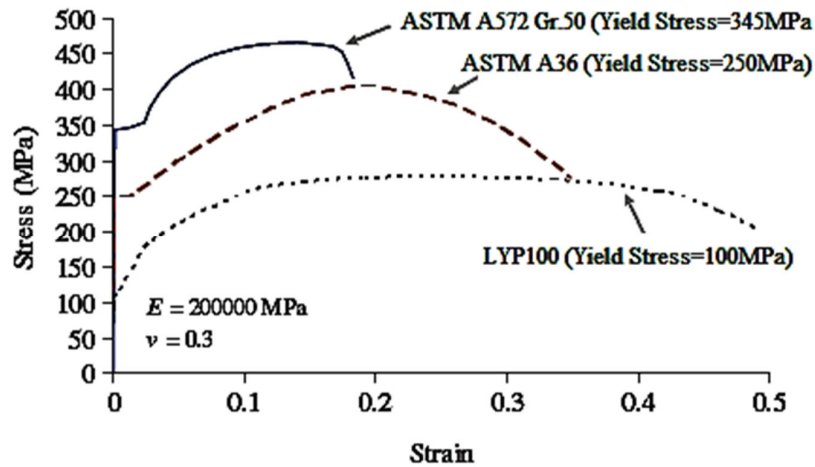
doi: 10.5267/j.esm.2022.11.003

wall with spherical appendage with different patterns on the LYP surface and thickness under cyclic and uniform load. In a study on examining the impact of sheet placement and changes in wave's characteristics on behavior of wavy steel shear wall, it was observed that steel shear wall capacity increased if waves were aligned with beams. Also, resistance of steel shear walls increases as wavelength decreases and wave depth increases (Ashrafi et al., 2018).

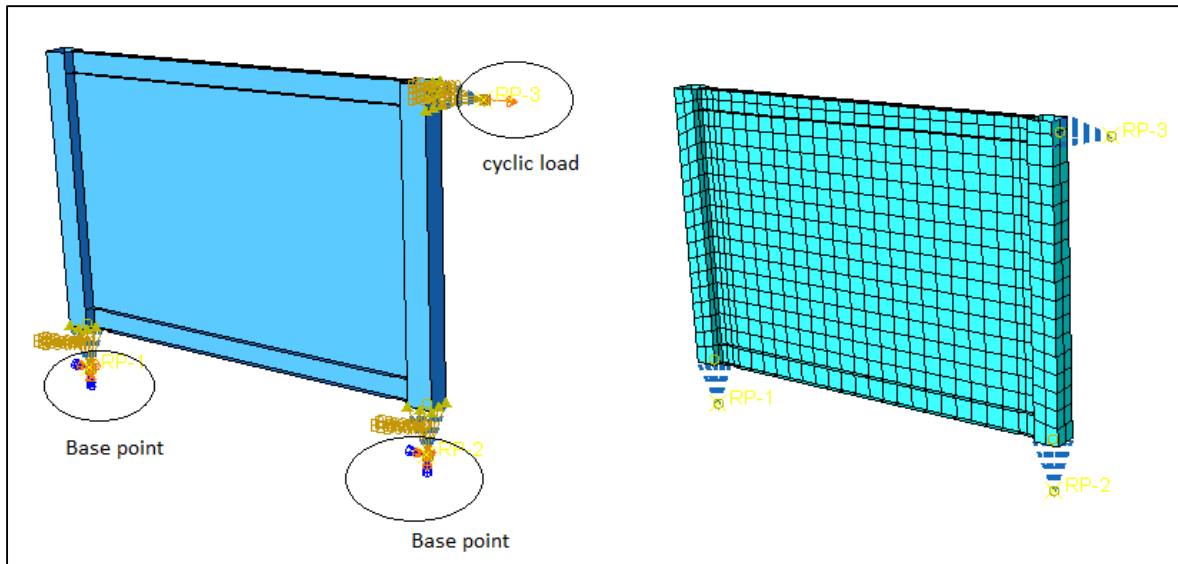
## 2. Materials and Methods

### 2.1 Verification

In 2015, an FEM study was conducted on LYP material for six models under cyclic load with ANSYS software. The accuracy and perfectness of the LYP model is compared to the model of (Zirakian & Zhang, 2015). H250×250×9×14 and H244×175×11 are used for making horizontal and vertical frames, and lateral load is imposed to top of the frame. Frame boundary conditions were assumed at the bottom of the columns and infill LYP steel plate was modeled with a shell in ANSYS by Zirakian and Zhang (2015) and ABAQUS in this paper. **Fig. 1** shows the stress – strain curve and **Fig. 2** depicts the model's dimension which has been chosen to introduce LYP plate to software. The connection between frame and ground is assumed rigid. Cyclic loading pattern has been selected according to Zirakian research. **Fig. 2** depicts locations of boundary condition and lateral load on the frame and also structural mesh 3D was used for solving this steel shear wall.



**Fig. 1.** Stress –strain curve for steel and LYP plate



**Fig. 2.** Load and support condition of shear steel wall

The result of FEM analysis for the LYP plate was compared to code design (Zirakian & Zhang, 2015). **Fig. 3** shows ABAQUS result for LYP wall and **Fig. 4** shows hysteresis cycle for ABAQUS. This figure shows that the result of this study has good agreement with guidelines.

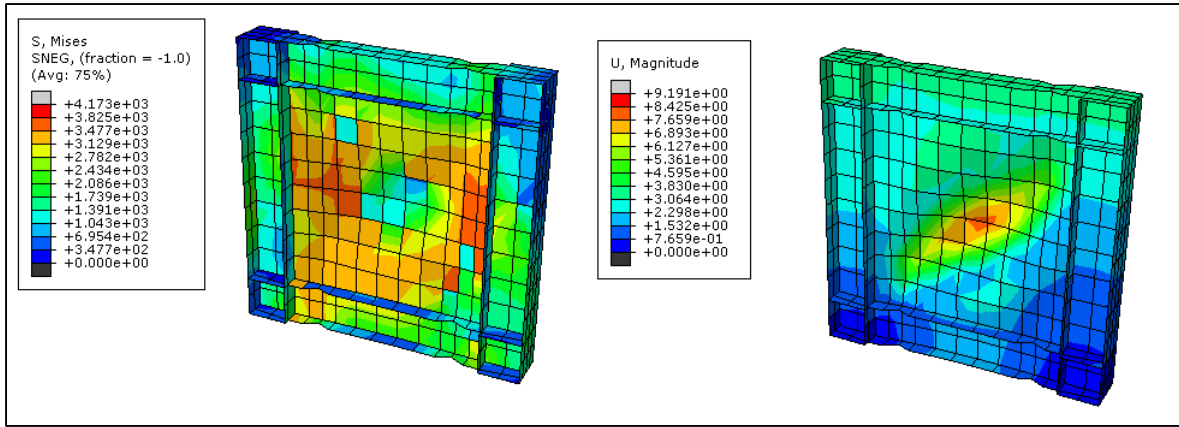


Fig. 3. ABAQUS result for present research

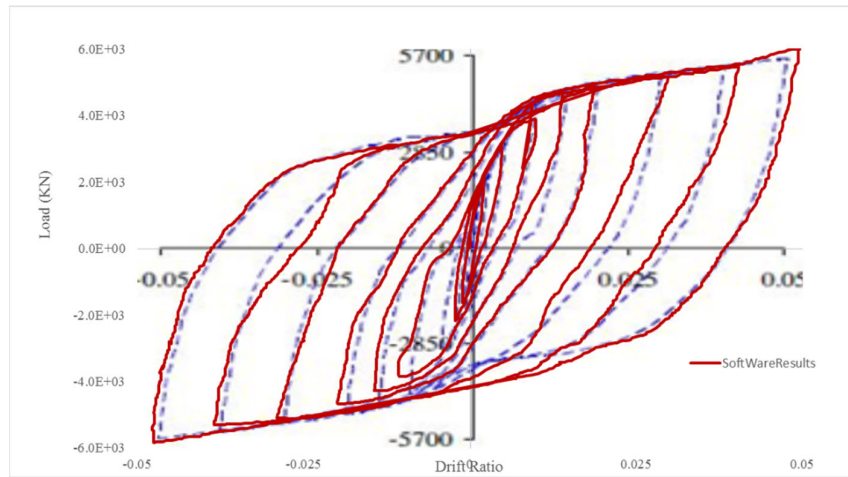


Fig. 4. Hysteresis loops for ABAQUS

2.2 Introducing research model

Parameters included in this research are maximum stress, historic circle and push over load. Spherical appendage is used on the plate with different dimensions (10 and 20 cm) and different patterns (diagonal and plus). Fig. 5 shows the column and beam section which is used for making shear walls.

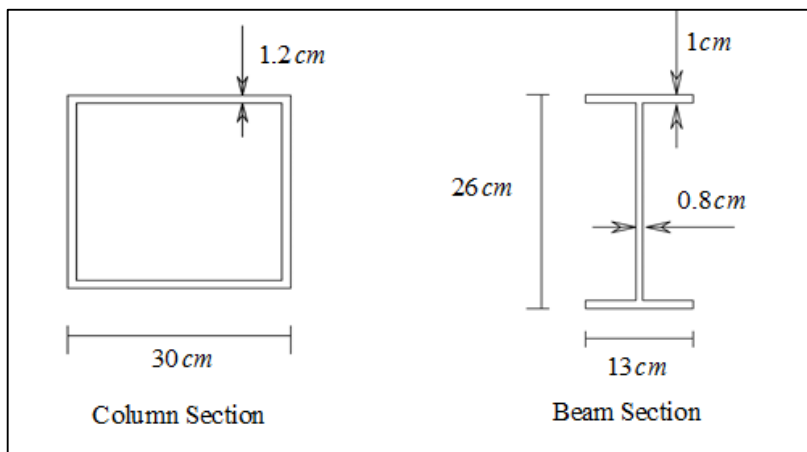
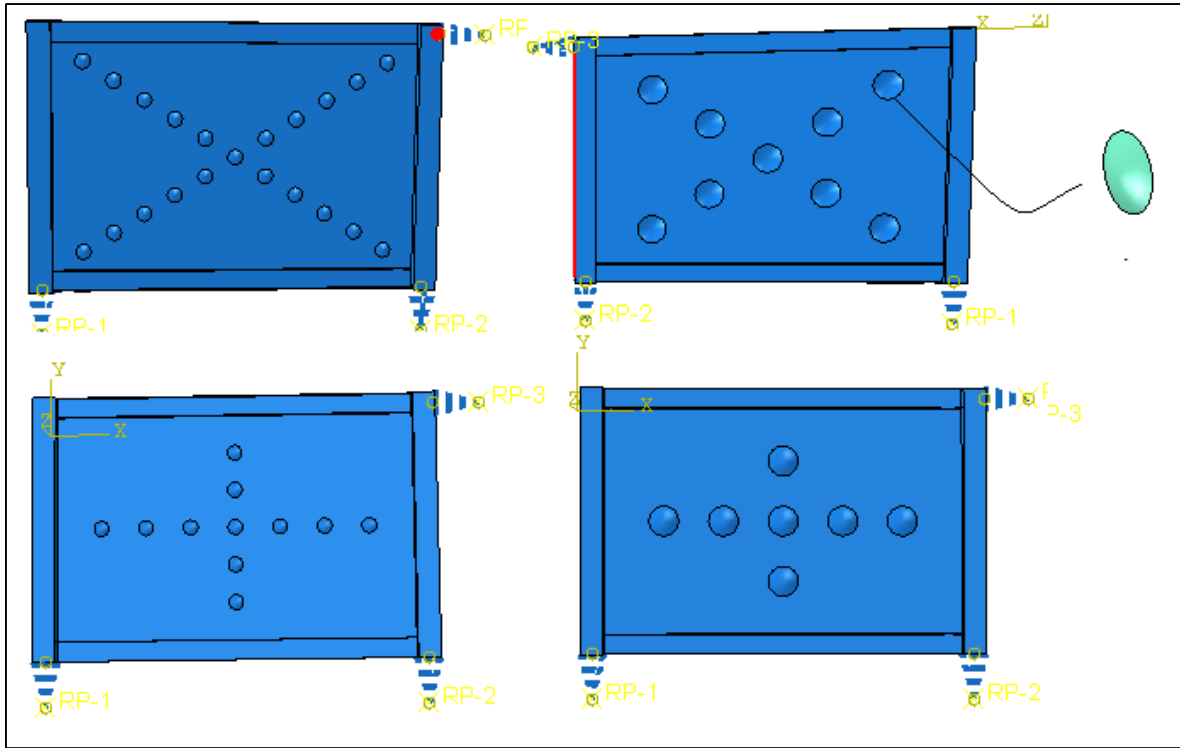


Fig. 5 Plate and frame dimensions of shear wall

Fig. 6 shows the pattern of spherical distribution. Five models have been analyzed in this research, model 1 is related to LYP plate, model 2 and 3 are related to LYP with 10 cm diameter in diagonal and plus pattern and model 4 and 5 are related to 20 cm spherical in two patterns.



**Fig. 6.** Pattern of spherical distribution on the infill plate

### 2.3 Design of Shear wall with infill plate

The workability of SPSW depends on the cross section of the infill plate. The efficiency of these structures is related to the infill plate's thickness. According to the past studies, the allowable maximum thickness of the plate is obtained via Eq. (1).

$$t_p = b * \sqrt{\frac{12 * (1 - v^2) * \sigma_{yp}}{\left(8.98 + \frac{5.6}{\left(\frac{a}{b}\right)^2}\right) * \pi^2 * E * \sqrt{3}}} \quad (1)$$

In the above formulation,  $E = 200000 \text{ MPa}$ ,  $v = 0.3$ ,  $\sigma_{yp} = 100 \text{ MPa}$ , and parameters  $a$  and  $b$ , are elastic modulus, Poisson's ratio and yield stress of LYP plate, maximum height and length of the infill plate, respectively. Characteristics of Shear walls with infill plate are introduced in Table 1, in these models,  $L$ ,  $h$  and  $t_p$  are respectively length, height, and thickness of the infill plate.

The result of this study is divided into four parts; part A includes base LYP plate, spherical distribution pattern and part B includes base LYP shear wall plate and shear wall plate with spherical appendage with different thickness (See Table 1).

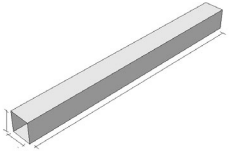
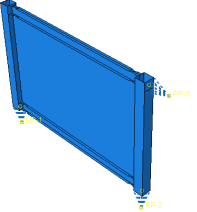
## 3. Result

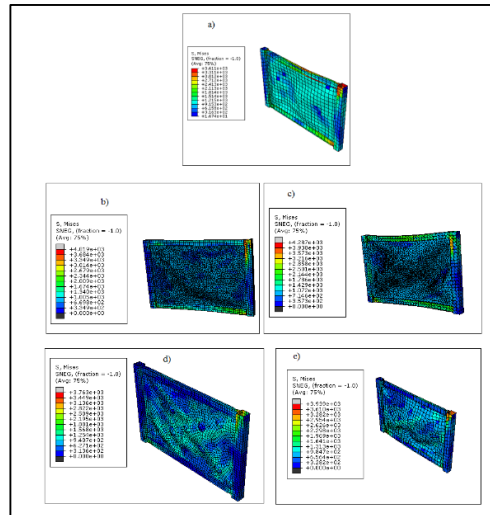
### 3.1 Group A (Infill plate with spherical pattern and LYP infill plate)

Stress contour are depicted with **Fig. 7** for five models, this result shows that diagonal pattern has the best performance in comparison with LSY and plus pattern since this model uses its entire capacity for observing load. The value of Von Mises stress is higher than plus and base LYP model, maximum stress occurred in the middle of LYP plate for all models.

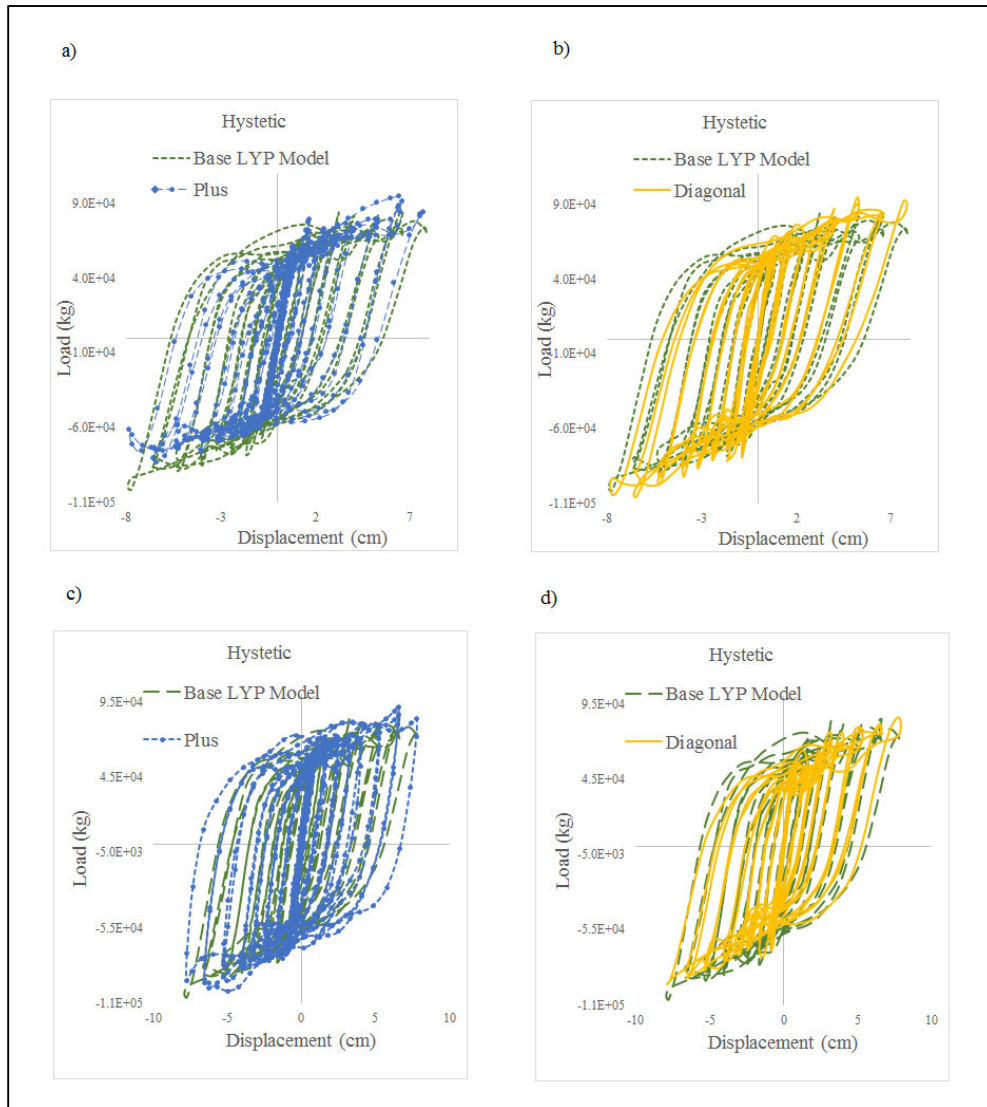
**Fig. 8** shows hysteresis cycle for LYP, 10cm and 20cm diameter for spherical appendage plate. **Fig. 9a** shows the hysteresis plot for a 10cm diameter spherical pattern. As can be clearly seen, the hysteresis cycle is fatter than two other models, so the plot area is higher than two other models, load observing is more than plus pattern; however, using plus pattern couldn't be so efficient in comparison with base LYP pattern. **Fig. 9b** shows the diagonal and plus pattern for 20 cm spherical pattern. The result of this study depicted this fact that enhancing diameter does not have any positive influence on the wall behavior because loading capacity decreases in comparison with case 1 (base LYP infill plate without spherical). In this case, where the spherical appendage diameter is 20 cm, plus pattern has higher load capacity than diagonal and base LYP plate.

**Table 1.** Features of SPSW models (with infill plates)

		<b>Plate</b>	<b>HBE (Beam)</b>	<b>VBE (Column)</b>	<b>Detail</b>
<b>Name</b>		Infill plate	Section		Plate
		LYP	ASTM A572 Gr. 50		Base LYP plate
					
<b>Group A</b>	SPSW1	2000×3000×6	W260×130×4800	W300×300×3520	LYP
	SPSW2	3000×3000×6	W260×130×4800	W300×300×3520	LYP + diagonal 10 cm semi-spherical
	SPSW3	3000×3000×6	W260×130×4800	W300×300×3520	LYP + Plus 10 cm semi-spherical
	SPSW4	3000×3000×6	W260×130×4800	W300×300×3520	LYP + diagonal 20 cm semi-spherical
	SPSW6	3000×3000×6	W260×130×4800	W300×300×3520	LYP + Plus 20 cm semi-spherical
<b>Group B</b>	SPSW7	3000×3000×3	W260×130×4800	W300×300×3520	LYP + diagonal 10 cm semi-spherical
	SPSW8	3000×3000×3	W260×130×4800	W300×300×3520	LYP + Plus 10 cm semi-spherical
	SPSW9	3000×3000×3	W260×130×4800	W300×300×3520	LYP + diagonal 20 cm semi-spherical
	SPSW10	2000×3000×3	W260×130×4800	W300×300×3520	LYP + Plus 20 cm semi-spherical
	SPSW11	3000×3000×12	W260×130×4800	W300×300×3520	LYP + diagonal 10 cm semi-spherical
	SPSW12	3000×3000×12	W260×130×4800	W300×300×3520	LYP + Plus 10 cm semi-spherical
	SPSW13	3000×3000×12	W260×130×4800	W300×300×3520	LYP + diagonal 20 cm semi-spherical
	SPSW14	2000×3000×12	W260×130×4800	W300×300×3520	LYP + Plus 20 cm semi-spherical
<b>Group C</b>	SPSW15	3000×3000×6	W260×130×4800	W300×300×3520	LYP + Plus pattern and 06 mm semi-spherical thickness
	SPSW16	3000×3000×6	W260×130×4800	W300×300×3520	LYP + Plus pattern and 12 mm semi-spherical thickness
<b>Group D (push analyses)</b>	SPSW1	3000×3000×6	W260×130×4800	W300×300×3520	Simple LYP plate
	SPSW2	3000×3000×6	W260×130×4800	W300×300×3520	LYP + diagonal 10 cm semi-spherical
	SPSW3	3000×3000×6	W260×130×4800	W300×300×3520	LYP + Plus 10 cm semi-spherical

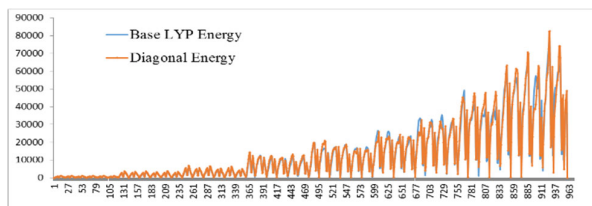


**Fig. 7.** Stress contour for infill LYP plate

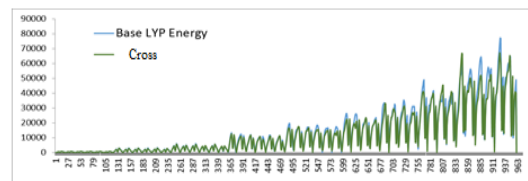


**Fig. 8.** Hysteresis cycle for base LYP model and different spherical pattern a) base LYP and 10 cm spherical appendage Plus pattern , b) base LYP and 10 cm spherical appendage diagonal pattern, c) base LYP and 20 cm spherical appendage plus pattern, d) base LYP and 10 cm spherical appendage diagonal pattern

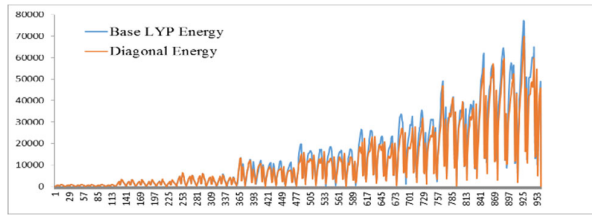
The kinetic energy of models 1-5 has been shown in **Fig. 9**. As these figures show, with 10 spherical diameters, the diagonal pattern and base LYP model have the highest energy absorption respectively and the plus pattern has the least energy absorption. Moreover, the absorbed stress for 10cm diameter in diagonal pattern is more than other states. Therefore, diameter increase does not have any positive effect on stress increase and energy absorption. In this state, if the appendage exists in this plate, it is better spherically distributed in a plus pattern.



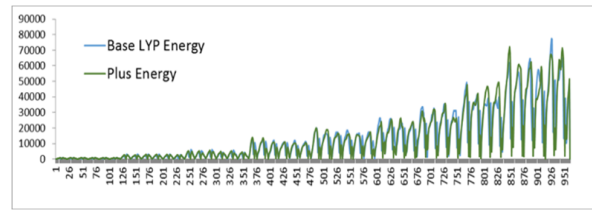
(a)



(b)



(c)

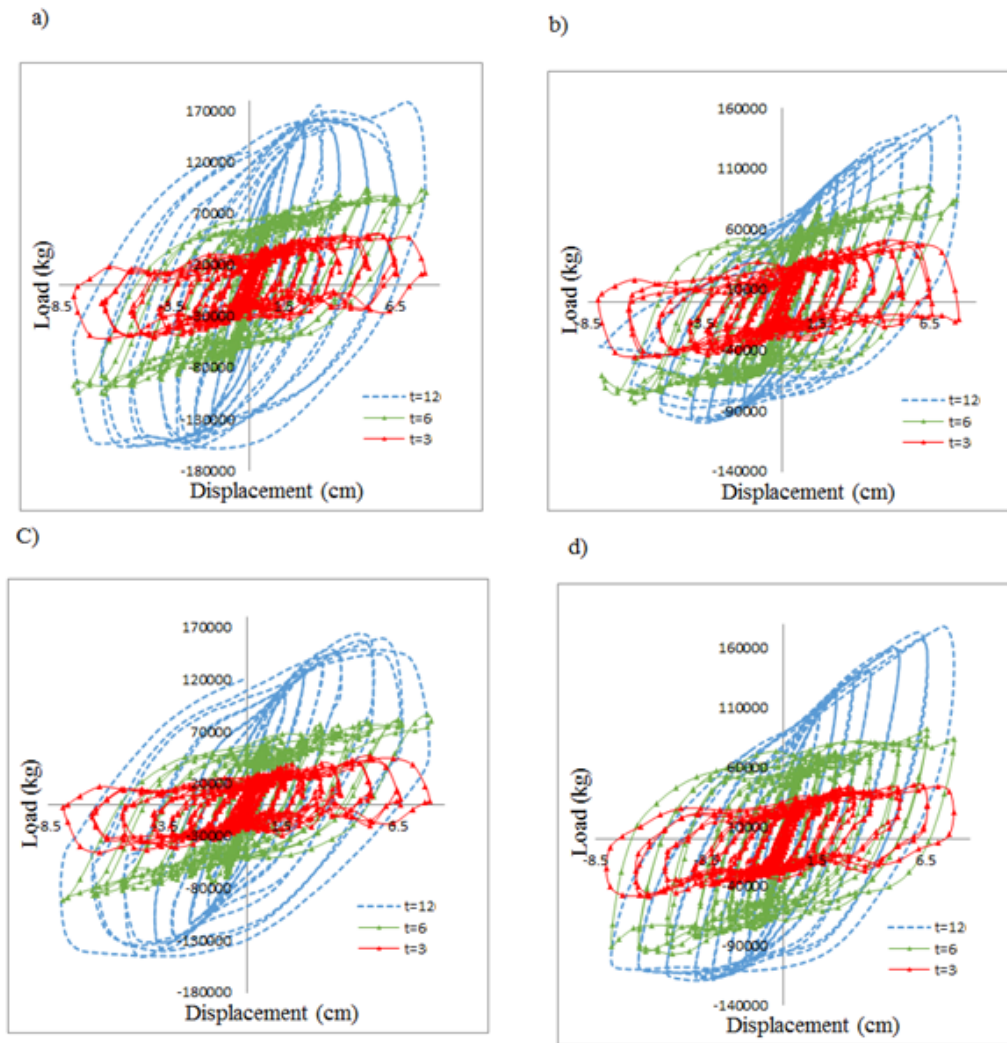


(d)

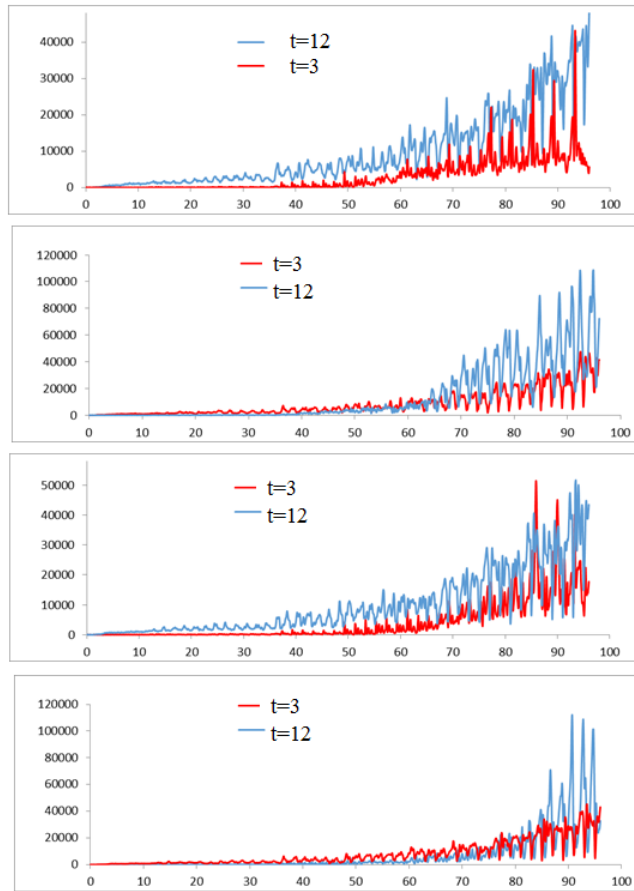
**Fig. 9.** Kinetic energy for base LYP model and different semi-spherical patterns a) Base LYP and 10 cm semi-spherical appendage with cross pattern b) Base LYP and 10 cm semi-spherical appendage diagonal pattern , c) Base LYP and 20 cm semi-spherical appendage cross pattern , d) Base LYP and 20cm semi-spherical appendage diagonal pattern

3.2 Group B (Infill plate with spherical pattern and LYP infill plate with different plate and spherical thickness)

In the following, the thickness of the plate is spherically assumed as a variable and the effect of thickness has been considered. **Fig. 10** shows hysteresis cycle and the kinetic energy has been shown with **Fig. 11**.



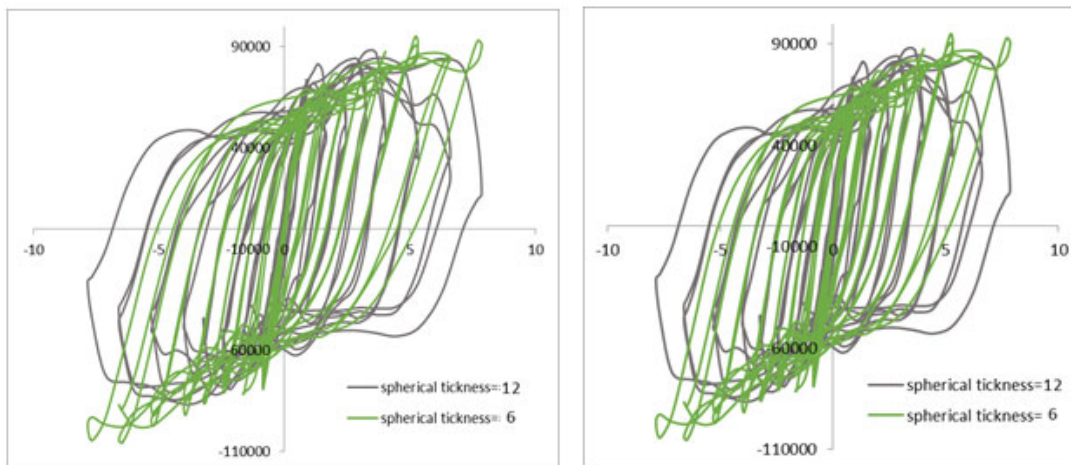
**Fig. 10.** Hysteresis loop for base LYP model and different spherical pattern with different thickness a) base LYP and spherical appendage with diagonal pattern , b) base LYP and 10 cm spherical appendage plus pattern, c) base LYP and 20 cm spherical appendage diagonal pattern, d) base LYP and 10 cm spherical



**Fig. 11.** Kinetic energy for base LYP model and different spherical patterns, with different thicknesses a) Base LYP and 10 cm semi-spherical appendage with cross pattern for  $t=03, 12$  b) Base LYP and 10 cm semi-spherical appendage cross pattern for  $t=3, 12$  c) Base LYP and 20 cm semi-spherical appendage diagonal pattern for  $t=3, 12$  d) Base LYP and 10 cm semi-spherical appendage diagonal pattern for  $t=3, 12$ mm

### 3.3 Group C (Infill plate with semi-spherical pattern, and with different thicknesses, in which LYP plate thickness is constant)

Finally, the thickness of the plate is considered constant, and the effect of semi-spherical appendage thickness has been considered. Hysteresis cycle has been shown with **Fig. 12**.



**Fig. 12.** Hysteresis loop for base LYP model and different semi-spherical pattern with different thickness a) Base LYP and 10 semi-spherical appendage with diagonal pattern, b) Base LYP and 10 cm semi-spherical appendage cross pattern



3.4 Group D (Push over analyses)

In this part of analysis, the pushover results for samples in group D were compared and shown in Fig. 13. For this purpose in group D, the load is statically exerted on the shear wall and the load-displacement diagrams are derived. For this aim, by keeping constant the projections' diameter we would deal with the arrangement of the projections. The comparison is made for plates having holes of 10 cm diameter. The maximum load acting on the shear wall with spherical load is in diametric form. The result shows the wall with diagonal pattern has the maximum ultimate load which has a higher stiffness with respect to other models of the shear wall and finally the uniform arrangement has the minimum stiffness. The yield force of the shear wall with spherical arrangement in the diametric case is 161 KN and in the uniform case is 982KN, which exhibits this fact that the stiffness of the shear wall is 1.60 times that of the uniform case. Where the wall with plus arrangement and spheres with 10cm diameter are used, the stiffness of the wall is 0.51 reduced with respect to spheres with 10cm diameter.

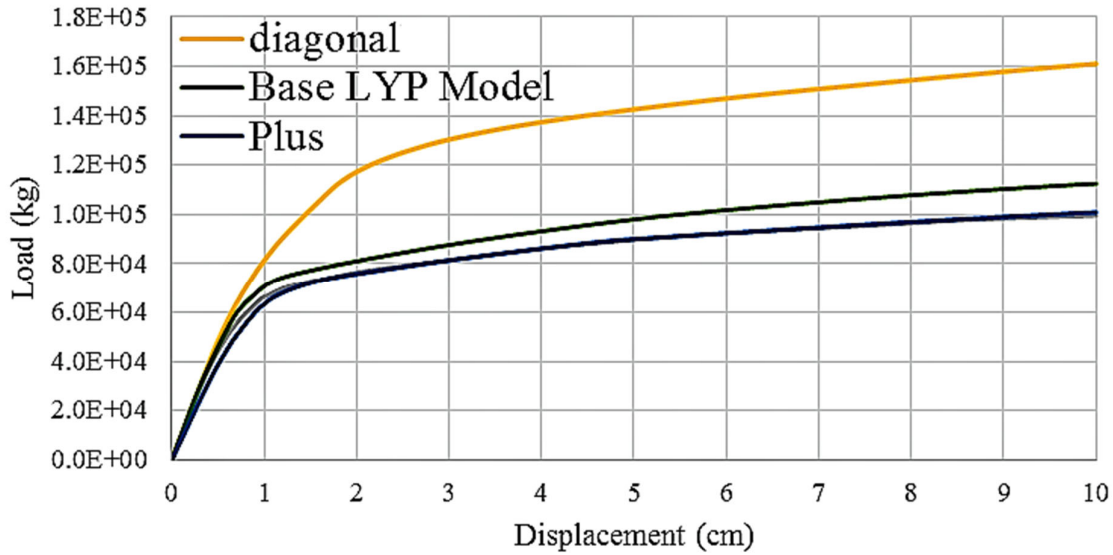


Fig. 13. Pushover analyses for base LYP model and different semi-spherical pattern with different pattern for group D

4. Discussion

The maximum absorbing force is related to a steel shear wall with diagonal pattern with 12 mm thickness and 10 cm appendage. In this case, the plot area and the absorbing force reaches to maximum value. Thickness increment decreases absorbing force and plot area. In all of the chosen thicknesses, the performance of the shear wall with 10 cm semi-spherical appendage is better than 20 cm semi-spherical appendage. Plot area for hysteresis cycle in diagonal pattern is bigger than cross pattern in models 4 and 5, while in the models 3 and 2 cross pattern is bigger than diagonal pattern. Overall, hysteresis cycle is more regular and obsesses in diagonal pattern, in comparison with cross pattern. Fig. 14 and Fig. 15 show the results. Because of the occurrence of inconsistency in these two models, increasing spherical thickness without increasing plate thickness does not have any positive effect on the LYP performance. Therefore, the plot area and absorbing force decreases in the last two models.

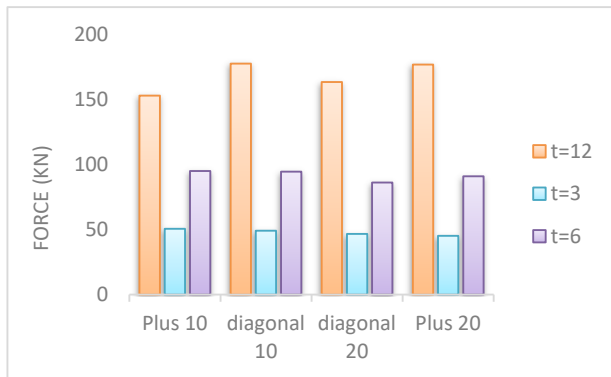


Fig. 14. Maximum value for force

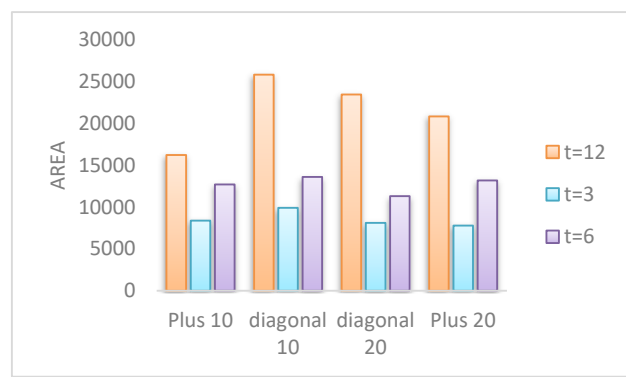


Fig. 15. Hysteresis area for all models

## 5. Conclusions

In this paper, a shear wall with spherical pattern is chosen for increasing nonlinear deformation and consequently increasing energy absorption and plot area. Beside it, due to achieve the aim of present study, the infill plate thickness in the SPSW model was increased from 3 mm to 12 mm and the structural behavior along with its components were investigated through finite element analyses. The result of this study is as follows:

- LYP steel has a low yield stress of about 90- 120 MPa which is approximately a third the amount of conventional ASTM A36 steel. This special low yield feature ensures an earlier yielding of the structure and, consequently, decreases the forces being imposed on the frame members to achieve a more enhanced lateral force-resisting and energy dissipating system for use in buildings. In fact, it has been noted that using LYP steel infill plates as recommended herein with higher thickness is not only easier to design, but also leads to prevent frames from collapsing . LYP steel shear walls may also be utilized to retrofit existing frame buildings requiring additional strength and stiffness, the hysteresis loop and also kinetic energy shows this fact.
- Using LYP leads to lateral stiffness decrease and energy absorption increase.
- Applying this spherical lead energy absorption and lateral stiffness increase in comparison with conventional steel.
- Using spherical in a plus pattern is not cost and time effective compared to diagonal pattern due to decreasing the stiffness.
- Increasing thickness leads to lateral stiffness increase in comparison with conventional steel.
- Increasing thickness in diagonal pattern leads to enhanced performance and workability of steel shear wall.

## References

- Ashrafi, H.R., Beiranvand, P., Pouraminian, M., & Moayeri, M.S. (2018). Examining the impact of sheet placement and changes in wave's characteristics on behavior of wavy steel shear wall. *Case Studies in Construction Materials*, 9, e00180.
- Boyajian, D., & Zirakian, T. (2016). Study on Buckling and Yielding Behaviors of Low Yield Point Steel Plates. *World Academy of Science, Engineering and Technology, International Journal of Civil and Environmental Engineering*, 10(9), 1166-1172.
- Chen, S.J., & Jhang, C. (2011). Experimental study of low-yield-point steel plate shear wall under in-plane load. *Journal of Constructional Steel Research*, 67(6), 977-985.
- Guo, H.C., Hao, J.P., & Liu, Y.H. (2015). Behavior of stiffened and unstiffened steel plate shear walls considering joint properties. *Thin-Walled Structures*, 97, 53-62.
- Jebelli, H., & Mofid, M. (2014). Effects of using low yield point steel in steel plate shear walls. *The IES Journal Part A: Civil & Structural Engineering*, 7(1), 51-56.
- Mistakidis, E. (2010). Numerical study of low-yield point steel shear walls used for seismic applications. *Engineering computations*, 27(2), 257-279.
- Nassernia, S., & Showkati, H. (2017). Experimental study of opening effects on mid-span steel plate shear walls. *Construction Steel Research*, 137, 8-18.
- Raisszadeh, A., Rahai, A., & Deylami, A. (2018). Behavior of Steel Plate Shear Wall in Multi Span Moment Frame with Various Infill Plate Connection to Column. *Civil Engineering Journal*, 4(1), 126-137.
- Shahi, N., & Adibrad, M.H. (2017). Finite-element analysis of steel shear walls with low-yield-point steel web plates. *Proceedings of the Institution of Civil Engineers-Structures and Buildings*, 171(4), 326-337.
- Vigh, L.G., Liel, A.B., Deierlein, G.G., Miranda, E., & Tipping, S. (2014). Component model calibration for cyclic behavior of a corrugated shear wall. *Thin-Walled Structures*, 75, 53-62.
- Wang, M., Fahnestock, L.A., Qian, F., & Yang, W. (2017). Experimental cyclic behavior and constitutive modeling of low yield. *Construction and Building Material*, 131, 696-712.
- Lv, Y., Li, L., Wu, D., Chen, Y., Li, Z. X., & Chouw, N. (2019). Shear-displacement diagram of steel plate shear walls with precompression from adjacent frame columns. *The Structural Design of Tall and Special Buildings*, 28(5), e1585.
- Zirakian, T., & Zhang, J. (2015). Buckling and yielding behavior of unstiffened slender, moderate, and stocky low yield point steel plates. *Thin-Walled Structures*, 88, 105-118.
- Zirakian, T., & Zhang, J. (2015). Seismic design and behavior of low yield point steel plate shear walls. *International Journal of Steel Structures*, 15(1), 135-151.

