

Artificial intelligence technologies utilization for detecting explosive materials

Ali Alshahrani^{a*}

^aFaculty of Computer Studies, Arab Open University, Saudi Arabia

CHRONICLE

ABSTRACT

Article history:

Received: July 2, 2023

Received in revised format: July 26, 2023

Accepted: August 23, 2023

Available online: August 23, 2023

Keywords:

Explosive Detection

Screening

Pattern Recognition

Artificial Intelligence

Security

Explosive material detection considers the identification and classification of explosive materials using techniques from traditional sniffer dogs to cutting-edge sensing technology like thermal imaging, X-ray scanners, and chemical sensors. Explosive detection is applied in various locations, including airports, government buildings, and public areas, to prevent terrorist attacks and criminal actions that attempt to employ explosive devices. The effectiveness of these procedures is dependent on the detection materials, equipment, and environment, so new techniques are continuously explored to increase precision, sensitivity, and detection speed. Because explosive substances present a critical risk to infrastructure, security, and public safety, extensive analysis of existing detection methods is needed. This paper highlights key areas for further research and development in explosive materials detection by addressing identified limitations and challenges. Specifically, advancements in technology, interdisciplinary collaboration, and the integration of AI techniques offer significant opportunities for improving detection accuracy, reducing false positives, and ensuring safer environments for individuals and society.

© 2024 by the authors; licensee Growing Science, Canada.

1. Introduction

Explosives are chemicals or materials that can undergo a quick and violent chemical reaction, releasing significant energy in the form of heat, light, sound, and gas. These substances are frequently employed for a variety of lawful activities, including mining, demolition, and fireworks displays. However, explosives can also be leveraged as weapons by criminals or terrorists, posing a serious risk to public security.

Explosives are classified as low explosives or high explosives, which are divided into multiple forms. High explosives explode at speeds of 1 km/s, and low explosives and propellants burn at relatively lower rates. Propellers, smokeless powder, black powder, and pyrotechnics are examples. The term "plastic explosive" refers to a flexible explosive, such as a sheet, comprised of one or more high explosives with a pure vapor pressure of less than 104 Pa at 25°C. When this type of explosive is fabricated with a binder, the resulting mixture is flexible and pliable at typical room temperatures (Suman, 2007).

Prevention and proactive responses to terrorist attacks, criminal activities, and even hazardous chemical accidents require effective detection of explosives and other dangerous materials. Many detection methods are available, from straightforward visual observation to cutting-edge systems, that can identify minute quantities of explosives and their precursors (Sharma et al., 2023; Klapac et al., 2020; Military Aerospace, 2020; Fisher, 2005). The most common method for finding explosives and hazardous materials features X-ray scanners, which produce images of the interiors of bags, packages, and other containers, enabling security officers to inspect suspicious objects or materials visually. Metal detectors are another type of device that can find metallic items, such as knives, firearms, and other covertly carried weapons (HTDS, 2022a). Chemical sensors react with particles from explosive compounds and can detect these substances in small quantities. Specially trained canines can

* Corresponding author.

E-mail address: a.shahrani@arabou.edu.sa (A. Alshahrani)

detect the presence of explosives and other dangerous materials by sniffing the air or surfaces (HTDS, 2022b). Mass spectrometry is a sensitive analytical method for determining and quantifying a suspect sample's chemical makeup, which can include minute amounts of explosives (Wg-PLC, 2022). Nuclear quadrupole resonance (NQR) is a non-invasive detection method that responds to the distinctive nuclear magnetic resonance signals of specific explosive compounds (Martz et al., 2022). Finally, infrared spectroscopy identifies the distinctive vibrational frequencies of molecules and enables the detection of explosive compounds based on chemical composition.

Because explosive materials pose a serious risk to public safety, discovering them in places like airports, public transportation, and high-risk buildings is essential to preventing attacks on people and infrastructure. An urgent need exists for more precise and effective explosive substance detection procedures because current detection techniques are frequently sluggish, laborious, and ineffective. Several variables, including the type of explosive or material, the location of the potential threat, and the required level of security, influence the selection of the most appropriate detection method. This research studies and analyses several explosive material detection methods and technologies to highlight their strengths and weaknesses. The contribution of our research identifies the gap between multiple methods and suggests new directions for future research consideration.

The remainder of the paper is organised as follows. Section 2 reviews existing detection methods, including analysing each method and listing their advantages and disadvantages. Section 3 further highlights this analysis with a discussion, followed by proposed future research directions in Section 4. Concluding remarks are provided in section 5.

2. Literature review

Multiple variables influence the study of technologies implemented for explosive material detection. This section examines the current state of the art in these technologies of the field and examines their various structures, techniques, and applications. Our comprehensive study also highlights areas where further research is needed to improve detection effectiveness and reliability.

To assist the safeguarding of special events, parking lots, and high-risk sites, the CarView gateway scan is presented in (HTDS, 2022a). Two top-down views of a scanned vehicle, including a high-quality, dual-energy transmission image and a Z Backscatter image, are produced concurrently by the system. The photo-like Z Backscatter picture provides better detection of organic threats, such as bombs, narcotics, and stowaways, while the dual-energy transmission image enables material differentiation technology to identify metallic and organic threats and contraband. This adaptable, affordable system is simple to transport, and its small size complies with the specifications for conventional tollbooth lanes. Coupled with a vehicle gate, exit bollards, vehicle protection kit, under-vehicle inspection system, license plate reader, scene cameras, a driver identification camera, and operator-alert software, the CarView portal is delivered as a component of an integrated, automated entry control-point solution. However, it requires specialised equipment, such as an FTIR spectrometer, which can be expensive with high maintenance requirements and depends on a high level of technical expertise to perform and interpret results.

The CLX (Chemical Agent Monitoring and Detection System) is a portable chemical detection system that can detect and identify a wide range of chemicals, including chemical warfare agents and toxic industrial chemicals (Wg-PLC, 2022). A combination of technologies, such as Ion Mobility Spectrometry (IMS) and Fourier Transform Infrared Spectroscopy (FTIR), analyse air samples and provide real-time identification of target chemicals. The device may be utilised at security checkpoints with very little operator training. The CLX is a powerful detecting device housed in a lightweight, robust thermoplastic casing designed to survive hard handling and challenging conditions. Without the need for carrier gases or radioactive isotopes, the portable CLX analyses particles and vapours in seconds.

The nuclear-based detection system proposed in (Martz et al., 2022) leverages a $^{14}\text{N}(p)^{13}\text{C}$ reaction used by nuclear reaction analysis (NRA) to probe the nitrogen content of baggage or cargo containers using high-energy (9.17-MeV) photons. This method is commonly known as gamma resonance absorption (GRA) because of its utilisation of incoming gamma rays. NRA possesses the high-energy photon penetration required for container inspection systems and has been studied for the detection of explosives in baggage and freight containers. Due to its use of gamma rays, NRA could be harmful to humans or consumable food if dose limits are exceeded.

The innovative approach presented in (Singh, et al., 2023) detects hidden explosives and drugs using an optimised graphene antenna in conjunction with terahertz (THz) spectroscopy (see Fig. 1). This technology overcomes the limitations of traditional detection methods, such as X-rays and metal detectors, that can pose risks to human health and may not detect all types of explosive materials. With its use of non-ionising radiation that is safe for people and its capabilities in detecting items hidden beneath non-metal materials, terahertz imaging and spectroscopy is recognised as a potential solution. The paper covers the construction of a multi-layered, dual-band graphene antenna using a uni-layer triple substrate approach for THz spectroscopic applications. A graphene-based dual-band antenna is created following this design, which employs silicon, Rogers RT5880, and Rogers RT 5880 LZ materials, and three substrates positioned at the same height. The enhanced graphene antenna resonates at the two frequencies of 5.59 THz for the detection of TNT explosives and 7.71 THz for medicines containing melatonin. These specific frequencies are employed due to their unique signature spectra in pure crystalline and other real-world forms. The antenna is deployed in a THz spectroscopy setup to send signals to a target and receive the target's echo waves, allowing for the detection of hidden explosives and drugs for various applications, such as public safety and counterterrorism.

However, the method is limited to materials with distinct signature spectra and encounters possible challenges in fabrication and integration due to the complexity of the antenna design.

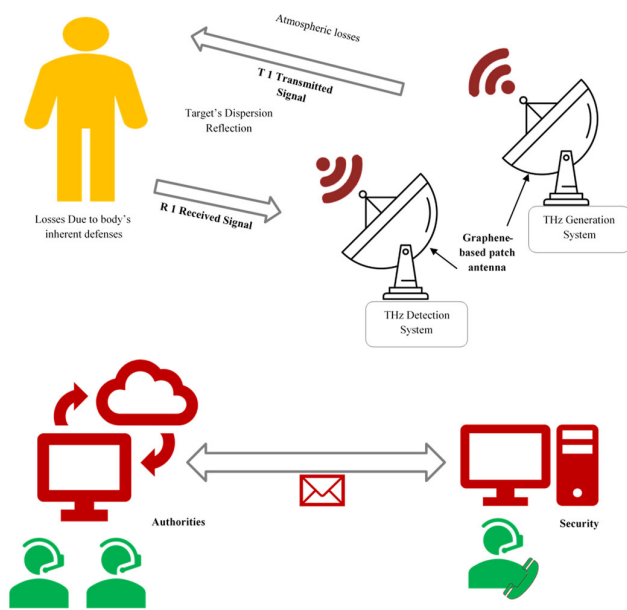

Fig. 1. Illustrative block diagram of THz spectroscopy (Singh, et al., 2023)

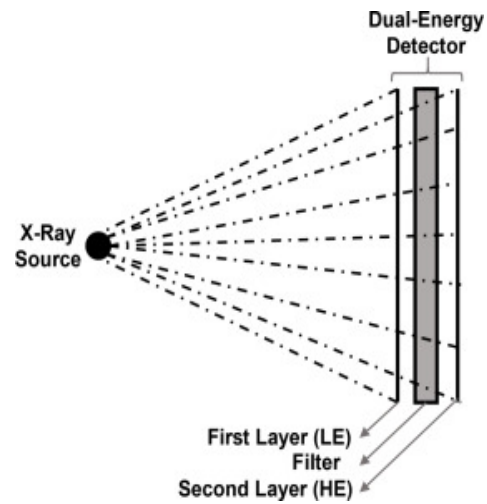

Fig. 2. Dual-energy detector topology (Yalçın & Reyhancan, 2022)

Dual-energy X-ray security systems are advanced X-ray devices used in security systems to detect explosive materials. These systems incorporate two energy levels to produce images of scanned objects, allowing for the estimation of the Effective Atomic Number (Z_{eff}) and material classification, as illustrated in Fig. 2. By calculating the linear mass attenuation coefficients (μ and μ') of the materials in the scanned object, the corresponding Z_{eff} values can be determined, which guides the classification of the substances as organic, inorganic, or metallic (Yalçın & Reyhancan, 2022). The dual-energy X-ray systems provide only a single view of the scanned object, which may not be sufficient to identify all potential threats accurately. Additionally, the X-ray sources in these systems expose the scanned objects and human operators to ionising radiation, which can be harmful if not properly managed. The external cavity quantum cascade laser (ECQCL) demonstrates a sensitive and quick detection method for explosives and dangerous compounds, according to (Ma et al., 2022) and as depicted in Fig. 3.

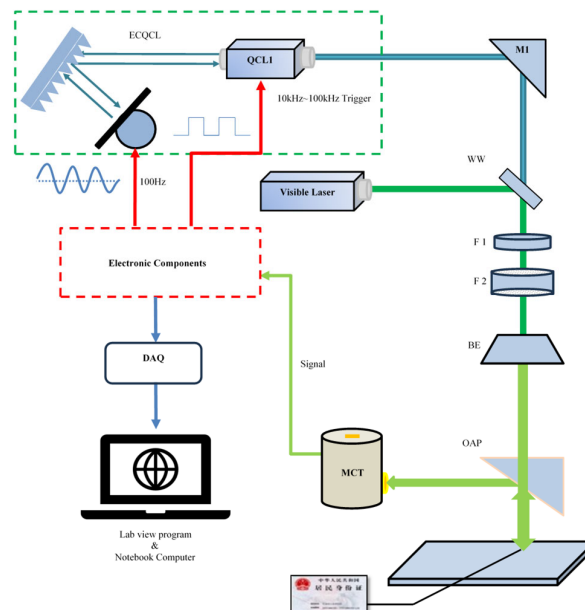

Fig. 3. A schematic illustration of the ECQCL sensing system (Martz et al., 2022)

The ECQCL's tuning element is a galvanometer, which achieves a high wavelength scanning speed. Through a single clock source, the driving module for the galvanometer and the analogue-to-digital conversion (ADC) module for data acquisition are synchronised. This synchronisation benefits from the quick scanning of the ECQCL while enabling exact data capture, preventing data dislocation and cumulative mistakes. For example, the system was tested on a Chinese Resident Identity (ID) Card containing trace amounts of adsorbed trinitrotoluene (TNT). Multiple averaging techniques enable the system's detection sensitivity of 1 g/cm² and detection speed of one result per second. A potential disadvantage of this technique may include producing erroneous data resulting from fast scanning, which increases the data processing complexity. In addition, the system was tested in a controlled laboratory environment with 50% humidity at 25°C, which may not represent real-world conditions. Finally, the width of the absorption peaks in the calibrated spectrum is wider compared to the HITRAN database due to instrumental broadening, which may affect detection accuracy.

The THREATID FTIR spectrometer is presented in (HTDS, 2022c), which is a modern chemical identifier called ThreatID that features enhanced usability, ergonomics, and performance to promote faster decision-making and increased confidence in the identification of unknown substances. Any material that contacts the diamond surface is probed by IR radiation resulting in an observable spectrum corresponding to the substance's distinctive pattern. More than 23,000 reference spectra of pure compounds and typical mixes, such as explosives and pharmaceutical derivatives, are included as standard data with ThreatID. For each reference entry, the Threat Assist onboard database provides further details, such as chemical names, synonyms, common usage, risks, PPE, and many more chemical features. Our analysis suggests limitations of this technology in usability and maintainability. The technology requires specialised equipment, such as an FTIR spectrometer, which can be expensive to purchase and maintain. In addition, it requires a high level of technical expertise to perform and interpret the results.

The method from (HTDS, 2022d) detects vapour from objects containing explosives using the fluorescence quenching of new polymer materials. These materials increase the quenching reaction when explosive chemicals bind to polymer films, a process that has enabled sensors toward performance levels beginning to resemble that of explosives-trained dogs. The polymers fluoresce brightly when exposed to light of the appropriate wavelength, making a Fido sensor. When the polymer contacts the gases of nitroaromatic explosives, like TNT, the fluorescence is reduced (i.e., quenched). A photodetector then detects this decrease in fluorescence intensity. The ability of these materials to quench the fluorescence of several polymer repeat units within a single molecular binding event makes them well-suited as sensing materials (i.e., fluorophores). Compared to conventional fluorescence quenching, a single fluorophore quenched upon contacting a molecule of a target analytic effectively enhances the quenching reaction. Currently, a low femtogram mass of TNT, or a vapour phase concentration of around 100 parts per quadrillion, may be detected by the nomadic sensor. One limitation observed with this technique is the requirement of specialised equipment, such as a sample collection device, which can be expensive to purchase and maintain. Additionally, it requires a high level of technical expertise to perform and interpret the results and may not be capable of detecting all types of explosives with low vapour pressures.

In vehicles with a control post, the UVTM research mirror enables quick and effective inspections, primarily for the defence of permanent installations and the battle against all forms of trafficking (HTDS, 2022e). This device is a powerful convex mirror with lights, positioned on skates, and utilised for study below a vehicle. For greater vehicle control, a long handle rotates to a horizontal position. A detachable and replaceable LED bulb may be used as a manual lamp to provide lighting. As a wheeled mirror, The UVTM has an ergonomic shape and built-in light source, making it adept for finding concealed bombs, weapons, and contraband. However, the UV beams can be harmful if used at short distances.

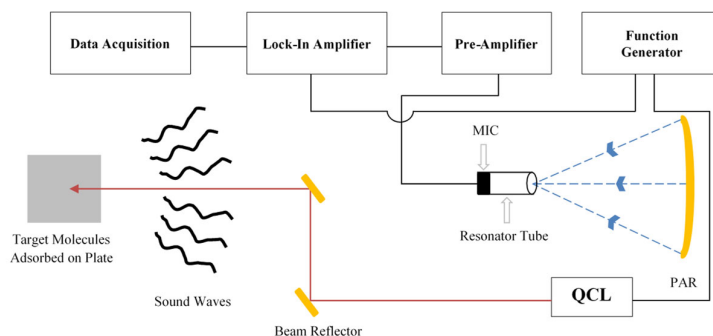

Fig. 4. Schematic of an experimental setup for a standoff laser photoacoustic sensor (Mann et al., 2021)

In (Mann et al., 2021), an alternative detection model is proposed that includes a tuneable Quantum Cascade Laser (QCL) as a light source, an ultrasensitive microphone as an acoustic detector, a cylindrical resonator tube, and a parabolic acoustic reflector as an acoustic detector for identifying dangerous chemicals and explosives adsorbed on surfaces from a standoff distance (see Fig. 4). The mid-infrared electromagnetic radiation generated by a QCL is absorbed by target molecules to produce acoustic or pressure waves. The parabolic reflector then gathers these waves and concentrates them on the resonator

tube, which are then detected by the connected microphone. This configuration yields a sensitivity of 2.0 g/cm^2 at a standoff distance of around 4.0 meters. Considering its limitations, the method may have an insufficient standoff distance for some applications. Additionally, the effectiveness of the technology may depend on environmental factors, such as humidity, temperature, and the presence of other gases, which can affect the photoacoustic signal. Practically, the setup requires specialised equipment, such as a tuneable QCL and ultrasensitive microphone, making it more complex and potentially expensive compared to other detection methods.

The creation of cerium (III)-melamine coordination polymer (CeM-CP) and its new explosive detection sensing properties are presented in (Elbasuney et al., 2021). CeM-CP responds to stimulation with a 100 mW UVA LED source at 385 nm by displaying distinctive spectrum fluorescence characteristics. Fluorescence signals at 400, 700, and 785 nm are produced because of this stimulation and are related to cerium coordinating with four nitrogen atoms and an available orbital for electron excitation migration. These signals are precisely measured using hyperspectral imaging, which yields a 3D depiction of the fluorescence signature. The key discovery of this work is that when CeM-CP is subjected to TNT vapours, total fluorescence signal attenuation occurs at 785 nm, making it a promising sensing material for explosive vapour detection. However, the method is limited to detecting only TNT vapours, and its performance might be affected by humidity and high temperatures.

A commercially available MIRcat QCL system with an IR optical fibre combiner attached to the front end of the QCL system comprises the IR optical fibre combined QCL (IRFC-QCL) device presented in (Major et al., 2019). The emission ranges of four QCL modules overlap, providing continuous emission coverage across the spectral range of 6.1–11.3 μm . According to (Major et al., 2019), and compared to previous QCL setups, this system is more reliable and streamlined because it does not require free-space optics. Inkjet printing on metal substrates of 1,3,5-Trinitro-1,3,5-triazinane (RDX) explosive samples was successfully detected at a standoff distance of 1 m. The RDX spectra collected and produced using a high-resolution FTIR setup showed reasonable agreement, suggesting that the IRFC-QCL system offers a practical substitute for detecting explosive residues on surfaces. However, the system requires technical expertise to operate and interpret results. In addition, the detection is limited to surface detection, potentially missing concealed threats within objects or containers.

The authors in (Puttasakul et al., 2019) discuss the development of a hydrogel-based electrochemical gas sensor for detecting explosive materials like trinitrotoluene (TNT). The technology uses polyacrylamide gel (PAAM) as the sensitive layer for explosive vapour sensing. By performing linear sweep voltammetry (LSV) measurements and analysing time-derivative signals, the sensor can identify different vapours based on unique interactions with the PAAM gel, enhancing its sensitivity and selectivity, as depicted in Fig. 5. However, The PAAM gel exposure time decreases as the working temperature increases, limiting its applicability in certain conditions.

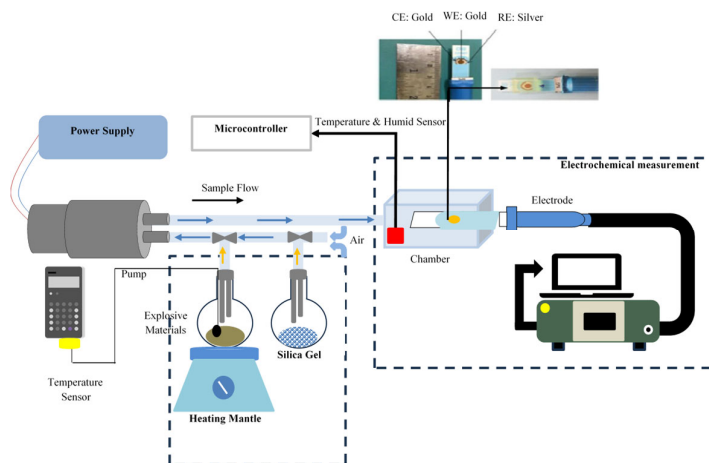

Fig. 5. A custom gas flow system for explosive vapour detection (Puttasakul et al., 2019)

A laser-induced breakdown spectroscopy (LIBS) is proposed in (Zhang et al., 2018) that features an emission spectrometric approach for analysing and detecting molecular and elemental fragments where the laser modifies the emission from the atoms and molecules. Recently, this laser-based approach has garnered interest in the detection of energetic compounds. Elements and molecule fragments from a variety of materials have been examined with LIBS, and it is considered a key technique for explosive detection because of its non-contact, rapid reaction, high sensitivity, real-time, and multi-element detection features. LIBS has been applied to detect biological, chemical, and explosive residues on multiple types of surfaces, including metals and polymers, while also demonstrating encouraging results in the analysis of complex biomaterial, and is a quick and effective approach for analysing chemicals and finding explosive and energetic component residue. Fig. 6 depicts a typical schematic design of a LIBS experimental setup.

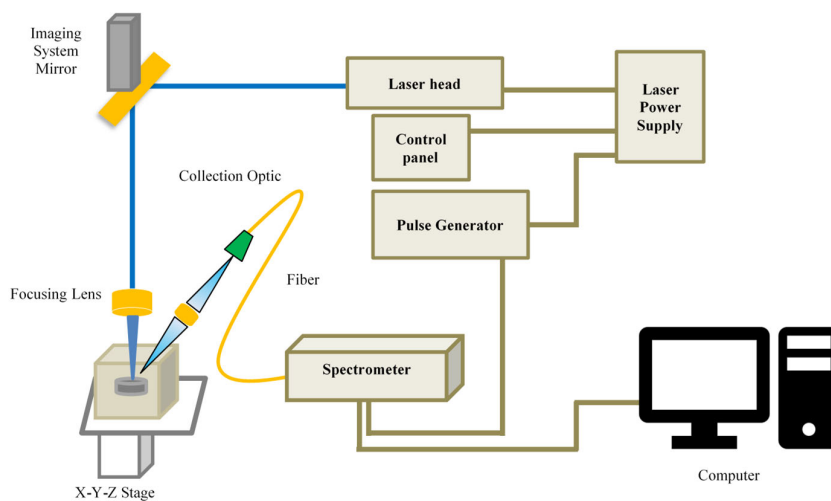

Fig. 6. Schematic diagram of a LIBS configuration (Zhang et al., 2018)

Fundamental Raman techniques applicable to homeland security applications include surface-enhanced Raman spectroscopy, resonance Raman spectroscopy, and spatially or temporally offset Raman spectroscopy. Novel Raman techniques are being developed for homeland security and defence purposes to enhance the Raman signal, lessen fluorescence effects, and remotely monitor hazards, such as remote Raman detection, Raman imaging, and Heterodyne imaging (CISA, 2016).

Considered a well-established method for detecting potentially dangerous or unlawful chemicals, Raman spectroscopy methods are non-destructive and may be used in the lab paired with state-of-the-art spectrometers or outdoors with portable equipment. Homeland security applications frequently demand that samples be positively and non-destructively identified to preserve the original sample's composition during subsequent laboratory analyses and make it accessible as possible evidence. Raman spectroscopy further preserves sample integrity by avoiding direct physical contact with the sample (Mogilevsky et al., 2012). However, this method is not appropriate for metals and alloys, and the Raman effect is relatively weak, requiring highly sensitive and optimised instrumentation for detection. Intense laser radiation can also heat the sample, cause damage, or obscure the Raman spectrum. Raman spectroscopy is also implemented in (HTDS, 2022b).

Tagged neutrons presented in (Viesti et al., 2008) can be used to detect explosives in vehicles, which supports the non-intrusive screening of automobiles and trucks, a crucial aspect of the battle against terrorism. Additionally, homemade liquid explosives (HME) have been used in multiple bombings worldwide, with devices concealed in automobiles and trucks and utilised by terrorists as vehicle-borne improvised explosive devices (VBIED). The Tagged Neutron Inspection System (TNIS) employs the neutron source $T(D,n)^4\text{He}$ reaction. A second-generation TNIS for cargo container inspection was developed as part of the EURITRACK project, financed by the EU's 6th Framework Programme. This technology uses a standard X-ray scanner in sequence with a tagged neutron probe to pinpoint the exact location of a questionable volume unit (voxel) inside the cargo. Radiation risk is reduced in this method by only inspecting these voxels with neutron beams.

Another technique used to detect explosives by chemiluminescence is presented in (Jimenez and Navas, 2007). Trace detection is defined as the chemical detection of explosives that gathers and analyses small quantities of explosive vapour or particles and searches for contamination or residue caused by handling or proximity. On many surface types, including Teflon, glass, metal, and plastic, particles of solid explosive material can adhere, which can then be found by wiping the surface. Because certain explosives have a low vapour pressure, vapour detectors are particularly sensitive when looking for the vapour emanating from a liquid or solid explosive.

The possibility of terahertz (THz) detection for imaging concealed weapons, explosives, and chemical and biological agents has drawn attention in recent years, which is influenced by three variables (Federici et al., 2005). First, terahertz radiation is easily transmitted through the majority of non-metallic and non-polar media. Second, various substances useful for security applications, such as explosives and chemical and biological agents, have distinctive THz spectra that may be utilised as a fingerprint to detect these hidden substances. Third, terahertz radiation does not or only minimally endangers the operator of the system or the suspect being scanned by the system. THz electromagnetic waves to spectroscopically detect and identify concealed materials by their distinctive transmission or reflectivity spectra in the range of 0.5–10 THz is one proposed method for identifying, detecting, and characterising concealed dangers. As for its limitations, terahertz radiation requires specialised equipment, such as a THz source and detector, which can be expensive to purchase and maintain and may not penetrate certain materials, such as metals and liquids.

Table 1 lists a summary of the most highlighted research in the detection of explosives materials, featuring the corresponding method, the use of AI techniques, pros and cons, and health implications.

Table 1
Summary of state-of-the-art explosive material detection techniques.

Method	AI Algorithm	Pros	Cons	Health Impact	Environment Factors
Fixed Portal CarView (HTDS, 2022a)	N/A	<ul style="list-style-type: none"> highly sensitive, which allows it to detect trace amounts of chemicals and explosives. 	<ul style="list-style-type: none"> It requires specialised equipment, such as a FTIR spectrometer, which can be expensive to purchase and maintain. Additionally, it requires a high level of technical expertise to perform and interpret the results. 	Risky if exceed doses limits	N/A
Raman Portable Spectrometer (HTDS, 2022b)	N/A	<ul style="list-style-type: none"> Its ability to identify a wide range of chemical compounds, including drugs and explosives. It can analyse samples without the need for sample preparation. 	<ul style="list-style-type: none"> It requires specialised equipment, such as a laser and a spectrometer, which can be expensive to purchase and maintain. It requires a high level of technical expertise to perform and interpret the results. 	Safe	N/A
CLX (Wg-PLC, 2022)	N/A	<ul style="list-style-type: none"> High level sensitivity, which allows it to detect trace amounts of chemicals. It is portability, which allows it to be used in a wide range of environments, including field applications. 	<ul style="list-style-type: none"> It requires a high level of technical expertise to perform and interpret the results. 	Safe	N/A
Nuclear-based detection (Martz et al., 2022)	N/A	<ul style="list-style-type: none"> highly sensitive, which allows it to detect trace amounts of chemicals and explosives. 	<ul style="list-style-type: none"> expensive to purchase and maintain. Additionally, it requires a high level of technical expertise to perform and interpret the results. 	Risky if exceed doses limits	N/A
GA based optimised graphene antenna using THz spectroscopy (Singh et al., 2023)	Genetic Algorithm	<ul style="list-style-type: none"> Better performance than conventional antennas Dual-band detection capability Optimised using genetic algorithms Smaller and more easily transportable. 	<ul style="list-style-type: none"> Possible challenges in fabrication and integration due to the complexity of the antenna design. Limited to materials with distinct signature spectra. 	Safe for low THz	N/A
Dual-energy X-ray (Yalçın & Reyhancan, 2022)	N/A	<ul style="list-style-type: none"> Dual-energy X-ray systems are more effective in detecting organic explosives compared to conventional systems that rely on density-based segmentation. These systems can classify substances as organic, inorganic, or metallic based on their Effective Atomic Number (Zeff), making it easier to identify potential threats. 	<ul style="list-style-type: none"> The current dual-energy X-ray systems only provide a single view of the scanned object, which may not be enough to accurately identify all potential threats. The use of X-ray sources in these systems exposes scanned objects and operators to ionising radiation, which can be harmful if not properly managed. 	Risky	N/A
External cavity quantum cascade laser (Ma et al., 2022)	N/A	<ul style="list-style-type: none"> With a detection speed of one result per second, the system meets the requirements for practical applications such as security checks at airports. The synchronisation between the driving module and the data acquisition module ensures precise data acquisition and avoids data dislocation. 	<ul style="list-style-type: none"> Fast scanning increases data processing complexity, which could lead to data errors. The system was tested in a controlled laboratory environment with 50% humidity and 25°C temperature, which may not represent real-world conditions. The width of the absorption peaks in the calibrated spectrum is wider compared to the HI-TRAN database due to instrumental broadening, which may affect detection accuracy. 	Safe	Affected by temperature and humidity
Threatid Ftir Spectrometer (HTDS, 2022c)	N/A	<ul style="list-style-type: none"> Can detect trace amounts of chemicals, including those that are difficult to detect using other technologies. It can be used to analyse samples without the need for sample preparation. 	<ul style="list-style-type: none"> Requires specialised equipment, such as a FTIR spectrometer, which can be expensive to purchase and maintain. Requires a high level of technical expertise to perform and interpret the results. 	Safe	N/A

Table 1
Summary of state-of-the-art explosive material detection techniques (Continued)

Method	AI Algorithm	Pros	Cons	Health Impact	Environment Factors
Ultra Lightweight Explosive Tracer Fido X3 (HTDS, 2022d)	N/A	<ul style="list-style-type: none"> Fido is portable, which allows it to be used in a wide range of environments. Its lightweight design makes it easy to carry and use, even in confined spaces. 	<ul style="list-style-type: none"> It requires specialised equipment, such as a sample collection device, which can be expensive to purchase and maintain. It requires a high level of technical expertise to perform and interpret the results. May not be able to detect all types of explosives with low vapour pressures. 	Safe	N/A
UYTM Research Mirror (HTDS, 2022e)	N/A	<ul style="list-style-type: none"> Easy visual inspection Stand-alone solution Handy and robust Day and night control 	<ul style="list-style-type: none"> Expensive to purchase and maintain. 	Risky on short limits	N/A
Remote mid IR Photoacoustic Spectroscopy (Mann et al., 2021)	N/A	<ul style="list-style-type: none"> The ability to detect hazardous materials from a distance allows for increased safety and minimises direct contact with dangerous substances. High sensitivity of detecting small concentrations of hazardous chemicals and explosives on surfaces, allowing for trace amount detection. The use of a resonator tube and parabolic acoustic reflector improves the signal strength and extends the detection range. The technology can be used for various applications, including defence. 	<ul style="list-style-type: none"> Limited to a standoff distance of approximately 4.0 meters, which may not be sufficient for some applications. The effectiveness of the technology may depend on environmental factors such as humidity, temperature, and the presence of other gases, which can affect the photoacoustic signal. The setup requires specialised equipment, such as a tunable QCL and ultrasensitive microphone, making it more complex and potentially expensive compared to other detection methods. 	Safe	Affected by temperature and humidity
3D spectral fluorescence signature of cerium(III)-melamine coordination polymer (Elbasoney et al., 2021)	N/A	<ul style="list-style-type: none"> Can be employed for remote sensing of explosive vapours, enhancing safety and detection accuracy. The use of hyperspectral imaging allows for precise measurement of fluorescence and quenching signals upon exposure to explosive vapours. 	<ul style="list-style-type: none"> The study focuses on the detection of TNT vapours, but not on other explosive vapours. The effectiveness of CeM-CP as a sensing material may be influenced by external factors such as humidity, temperature, and the presence of other vapours. 	Safe	Affected by temperature and humidity
Fiber Optic Coupled Quantum Cascade Infrared Laser System (Major et al., 2019)	N/A	<ul style="list-style-type: none"> Robust and streamlined design, eliminating the need for free-space optics. Capable of detecting explosive materials on surfaces at a standoff distance of 1 m. 	<ul style="list-style-type: none"> System complexity. Requires technical expertise to operate and interpret results. Limited to surface detection, potentially missing concealed threats within objects or containers. 	Safe	
Hydrogel-based electrochemical gas sensor (Puttasakul et al., 2019)	N/A	<ul style="list-style-type: none"> It absorbs explosive vapours and achieve high sensitivity in detecting low vapour pressure compounds like TNT. The sensor can detect changes in gas absorption within two minutes, which is faster than some other similar approaches that take five minutes or longer. 	<ul style="list-style-type: none"> The PAAM gel exposure time decreases as the working temperature increases, limiting its applicability in certain conditions. The current study only used one type of gel without any functionalisation to make it selective to TNT. 	Safe	Affected by temperature

Table 1
Summary of state-of-the-art explosive material detection techniques (Continued)

Method	AI Algorithm	Pros	Cons	Health Impact	Environment Factors
Laser-induced breakdown spectroscopy (Zhang et al., 2018)	N/A	<ul style="list-style-type: none"> It is a non-destructive technique, meaning that it does not damage the sample during the analysis process. It can be used to analyse a wide range of samples, including solids, liquids, and gases. It can analyse samples without the need for sample preparation. 	<ul style="list-style-type: none"> It requires specialised equipment, such as a laser and a spectrometer, which can be expensive to purchase and maintain. It requires a high level of technical expertise to perform and interpret the results. 	Safe	N/A
Raman Spectroscopy (Mogilevsky et al., 2012)	N/A	<ul style="list-style-type: none"> Raman spectroscopy can analyse solids, liquids, polymers and vapours, both organic and inorganic. It that it does not require any sample preparation. The spectra can be obtained within seconds, and samples can be analysed even if they are packaged in glass or a polymer. 	<ul style="list-style-type: none"> Can't be used on metals or alloys. The Raman effect is relatively weak, which requires highly sensitive and optimised instrumentation for detection. Intense laser radiation can heat up the sample and cause damage or obscure the Raman spectrum. 	Safe	N/A
Tagged Neutrons (Viesti et al., 2008)	N/A	<ul style="list-style-type: none"> It can detect both metallic and non-metallic explosives, making it a versatile technique. It can detect explosives that may be hidden in hard-to-reach areas of a vehicle. It is non-destructive, meaning that it does not damage the vehicle or its contents during the inspection process. 	<ul style="list-style-type: none"> It requires specialised equipment, such as a neutron generator and gamma ray detector, which can be expensive to purchase and maintain. It requires a high level of technical expertise to perform and interpret the results. Tagged neutron inspection may not be able to detect all types of explosives, and may not work well in vehicles with high levels of shielding or heavy metal content. 	Risky if not handled properly	N/A
Chemiluminescence (Jimenez & Navas, 2007)	N/A	<ul style="list-style-type: none"> Chemiluminescence can detect extremely low levels of explosive compounds, making it useful for sensitive applications. Different Chemiluminescence reagents can be used to detect specific types of explosive compounds, allowing for selective detection. Chemiluminescence detection devices can be small and portable, making them useful for field applications. Chemiluminescence is relatively inexpensive and easy to perform. 	<ul style="list-style-type: none"> Chemiluminescence can produce false positive results if the reagents react with other compounds that are not explosive. Other chemicals in the sample can interfere with chemiluminescence reaction, reducing the sensitivity or specificity of the detection. Humidity and temperature can affect the performance of the chemiluminescence reagents, making it necessary to control the environment to get accurate results. Some chemiluminescence reactions can be complex and may require a high level of technical expertise to perform and interpret the results. 	Safe	Affected by temperature and humidity
THz imaging and sensing (Federici et al., 2005)	N/A	<ul style="list-style-type: none"> Its ability to penetrate many non-conductive materials, such as plastics and ceramics, making it useful for imaging and sensing through opaque objects. THz radiation can be used to detect the presence of certain chemical compounds, such as drugs and explosives, by analysing their unique absorption or scattering spectra. 	<ul style="list-style-type: none"> It requires specialised equipment, such as a THz source and detector, which can be expensive to purchase and maintain. It requires a high level of technical expertise to perform and interpret the results. May not be able to penetrate certain materials, such as metals and liquids. 	Safe	N/A

3. Discussion and analysis

In the previous section, we reviewed various technologies for detecting explosive materials, including nuclear-based detection, chemical detection, dual-energy X-ray security, and external cavity quantum cascade lasers, including highlights of advantages and limitations. These limitations suggest areas where further research is necessary to improve the effectiveness, safety and reliability of these detection technologies.

Various scientific approaches for detecting explosive materials were also reviewed in the previous section. However, some of these methods involve applicability and detection range limitations and require advanced technical expertise to operate. Most methods described here differ in how they use radiation and respond to chemical interactions. Some incorporate non-ionising radiation, making them safe for humans, while others use nuclear reactions and X-rays, which may be harmful if not properly managed. Chemical detection methods use a combination of technologies, such as IMS and FTIR, to identify the chemical composition of materials. Each method offers strengths and limitations and is suitable for specific applications.

AI technologies have demonstrated tremendous potential in many fields, from healthcare to finance and security. However, leveraging AI methods for explosive materials detection is not yet widespread, as seen in the summarisation in Table 1, which we suggest is the results of several reasons. First, detecting explosive materials requires highly specialised and domain-specific knowledge, which is often difficult to curate and process for AI models. Developing performant AI models that support explosive material detection requires significant training data, which can be challenging to obtain due to the risks and safety concerns in handling and storing explosives. Such a lack of data can lead to overfitting or underfitting AI models, making them ineffective or unreliable in real-world scenarios.

Second, explosive material detection often requires highly complex and multi-faceted analyses of a range of variables, including physical properties, chemical properties, and other unique characteristics of the materials. These complex analyses are challenging to automate using AI techniques and may require sophisticated equipment and specialised expertise, which affect the scalability of such methods in low-income countries. Moreover, explosive material detection methods often involve sophisticated equipment that can be challenging to integrate with AI techniques. These integrations can require significant time, resources, and technical expertise.

Finally, ethical and legal concerns exist associated with the use of AI in explosive material detection. For example, breaches in privacy may arise through the data collected during detection that could contain sensitive information about individuals. Additionally, limited accuracy and reliability of the predictive results from trained AI models could lead to serious consequences if they produce false positives or false negatives.

4. Future Research Directions

While currently available explosive materials detection methods feature improved security measures, there remains a need for further research to enhance their efficacy and overcome existing limitations. Based on our analysis, we propose the following future research directions to advance the field:

- Advanced sensor development could alleviate limitations in sensitivity and selectivity in many available sensors. Researchers can explore new materials, such as nanomaterials, to detect trace amounts of explosive materials. For example, nanowires or nanoparticles can enhance the sensitivity of sensors, while surface-enhanced Raman spectroscopy (SERS) can improve selectivity.
- Combining multiple detection technologies can improve detection accuracy and reduce false positives. For example, combining chemical and radiation sensors into a single device that detects explosives and radioactive materials could also be integrated with biological sensors for detecting biological agents. Integration of multiple detection technologies can also improve the reliability of the system by reducing the likelihood of a single point of failure.
- AI and machine learning can improve the speed and accuracy of detecting explosive materials. These techniques can analyse vast amounts of data to identify patterns and establish predictive models for quickly identifying potential threats. Researchers could develop algorithms that learn from data in real-time, enabling practical detection of threats.
- Explosive material detection systems can struggle to detect explosives in complex environments, such as those with multiple interfering materials. Research into advanced signal processing techniques, such as machine learning algorithms, could improve detection accuracy in complex environments. Additionally, researchers could develop advanced algorithms that differentiate between types of materials, such as plastics or metals, to reduce false positives.
- Drones can deliver detection equipment to remote or hard-to-reach areas. For example, a drone can place a chemical sensor within a location inaccessible to security personnel, allowing for the remote detection of explosives without placing personnel at risk. Additionally, drones equipped with environmental sensors can monitor surrounding conditions, such as temperature, humidity, and air quality, which impact the performance of explosive material detection devices. By providing real-time data on these environmental conditions, drone support can optimise the performance of detection equipment and improve accuracy.

- Drones can be integrated with AI and machine learning algorithms to further improve detection accuracy. For example, a drone equipped with a chemical sensor and an onboard processor with a machine learning algorithm could quickly identify explosive materials, differentiate them from harmless materials, and reduce false positives.

These proposed research directions could significantly improve the accuracy and reliability of explosive materials detection methods, leading to a safer and more secure environment for everyone. AI may offer tremendous potential in explosive material detection methods, but its use remains limited due to the challenges of creating accurate and reliable models. Despite these challenges, ongoing research and development in this field continue to explore the use of AI in explosive material detection, with the aim of improving the effectiveness and reliability of explosive detection.

5. Conclusion

This paper presents an analysis of various technologies and proposed research directions in the field of explosive materials detection. The strengths and limitations of detection methods, including nuclear-based systems, chemical detection techniques, and advanced spectroscopy approaches, are examined. While each method offers unique advantages, significant challenges remain that must be addressed to enhance effectiveness, reliability, and safe use.

A key recommendation of the paper is the need for further research and development to support several areas. Advanced sensor development using nanomaterials emerges as a promising avenue to improve detection sensitivity and selectivity. Another crucial idea highlighted is the potential of combining multiple detection technologies. By adopting the integration approach, the reliability and effectiveness of the detection system can be enhanced, reducing the likelihood of false positives and improving overall security measures.

The integration of AI and machine learning algorithms represents a significant opportunity for advancing explosive materials detection methods because these techniques can analyse vast amounts of data, identify patterns, and create predictive models to identify potential threats. By continuously learning from real-time data, AI models can adapt and improve detection capabilities, enabling faster and more accurate identification of explosives in real-world scenarios. However, addressing the challenges related to obtaining and managing sufficient training data and ensuring the accuracy and reliability of AI models remains crucial.

Additionally, the paper emphasises the importance of addressing detection challenges in complex environments. Exploring the use of drones for explosive material detection in remote or hard-to-reach areas is another promising research direction.

Researchers can create more effective, reliable, and efficient detection methods by addressing the limitations and challenges identified. Continued technological advancements, interdisciplinary collaboration, and the integration of AI techniques can improve detection accuracy by reducing false positives. As a result, the proposed future research could lead to a safer and more secure environment for individuals and societies around the world.

Acknowledgment

The author would like to thank the Arab Open University, Saudi Arabia for supporting this research.

References

- CISA, (2016). Vehicle-Borne Improvised Explosive Device Detection Course (PER-312). <https://www.cisa.gov/resources-tools/training/vbied-detection-course-312> (accessed May 25, 2023)
- Elbasuney, S., Baraka, A., Gobara, M., & El-Sharkawy, Y. H. (2021). 3D spectral fluorescence signature of cerium (III)-melamine coordination polymer: a novel sensing material for explosive detection. *Spectrochimica Acta Part A: Molecular and Biomolecular Spectroscopy*, 245, 118941.
- Federici, J. F., Schulkin, B., Huang, F., Gary, D., Barat, R., Oliveira, F., & Zimdars, D. (2005). THz imaging and sensing for security applications—explosives, weapons and drugs. *Semiconductor science and technology*, 20(7), S266.
- Fisher, M., Sikes, J., Prather, M., & Wichert, C. (2005). Detection of vehicle-based improvised explosives using ultra-trace detection equipment. *In Proc. of SPIE - The International Society for Optical Engineering*, 5778, 383–392.
- HTDS. (2022a). Fixed portal CarView . HTDS. <https://www.htds.fr/en/security/x-ray-scanner/cargo-x-ray-scanner/x-ray-backscatter-cargo-solution/fixed-portal-carview/> (accessed May 27, 2023)
- HTDS. (2022b). Raman portable spectrometer FirstDefender RM/RMX. HTDS. <https://www.htds.fr/en/security/cbrn-detectors/chemical-risks/optical-portable-spectrometers/raman-portable-spectrometer-firstdefender-rm-rmx/> (accessed May 20, 2023)
- HTDS. (2022c). ThreatID FTIR Spectrometer. <https://www.htds.fr/en/security/explosif-and-narcotic-detectors/identification-spectrometers/threatid-ftir-spectrometer/> (accessed May 20, 2023)
- HTDS. (2022d). Ultra Lightweight Explosive Tracer FIDO X3 . <https://www.htds.fr/en/security/explosif-and-narcotic-detectors/traces-detectors/ultra-lightweight-explosive-tracer-fido-x3/> (accessed May 15, 2023)
- HTDS. (2022e). UVTM research mirror . <https://www.htds.fr/en/security/explosif-and-narcotic-detectors/uvtm-research-mirror/> (accessed May 30, 2023)
- Jimenez, A. M., & Navas, M. J. (2007). Detection of explosives by chemiluminescence. In *Counterterrorist Detection*

- Techniques of Explosives* (pp. 1-39). Elsevier Science BV.
- Klapec, D. J., Czarnopys, G., & Pannuto, J. (2020). Interpol review of detection and characterization of explosives and explosives residues 2016-2019. *Forensic science international: Synergy*, 2, 670-700.
- Ma, Y., Ding, K., Wei, L., Li, X., Shi, J., Li, Z., ... & Xu, D. (2022). Research on Mid-Infrared External Cavity Quantum Cascade Lasers and Applications. *Crystals*, 12(11), 1564.
- Major, K. J., Shaw, L. B., Busse, L., Gattass, R., Arnone, D., Lopez, E., ... & Ewing, K. J. (2019). Fiber optic coupled quantum cascade infrared laser system for detection of explosive materials on surfaces. *Optics & Laser Technology*, 119, 105635.
- Mann, M., Rao, A. S., & Sharma, R. C. (2021). Remote mid IR Photoacoustic Spectroscopy for the detection of explosive materials. *Chemical Physics Letters*, 765, 138231.
- Martz Jr, H. E., & Glenn, S. (2022). Nuclear techniques to detect explosives. In *Counterterrorist Detection Techniques of Explosives* (pp. 339-381). Elsevier.
- Military Aerospace. (2020). Customs and Border Protection picks Smart Imaging Systems for explosives-scanning sensors for cars and trucks. Military Aerospace. <https://www.militaryaerospace.com/sensors/article/14187840/sensors-explosives-cars-and-trucks> (accessed May 25, 2023)
- Mogilevsky, G., Borland, L., Brickhouse, M., & Fountain III, A. W. (2012). Raman spectroscopy for homeland security applications. *International Journal of Spectroscopy*, 2012.
- Puttasakul, T., Pintavirooj, C., Sangma, C., & Sukjee, W. (2019). Hydrogel based-electrochemical gas sensor for explosive material detection. *IEEE Sensors Journal*, 19(19), 8556-8562.
- Sharma, M., Sharma, B., Gupta, A. K., & Pandey, D. (2023). Recent developments of image processing to improve explosive detection methodologies and spectroscopic imaging techniques for explosive and drug detection. *Multimedia Tools and Applications*, 82(5), 6849-6865.
- Singh, G., Sandha, S., & Kansal, A. (2023). GA based optimized graphene antenna design for detection of explosives and drugs using THz spectroscopy. *Micro and Nanostructures*, 179, 207566.
- Singh, S. (2007). Sensors—An effective approach for the detection of explosives. *Journal of hazardous materials*, 144(1-2), 15-28.
- Viesti, G., Donzella, A., Bonomi, G., Botosso, C., Fabris, D., Lunardon, M., ... & Zenoni, A. (2008). Search of explosives in vehicles by using tagged neutrons. In *Detection of Liquid Explosives and Flammable Agents in Connection with Terrorism* (pp. 39-46). Springer Netherlands.
- Wg-PLC. (2022). CLX Trace explosives and HME precursors detector. Wg-PLC. <https://www.wg-plc.com/product/clx-trace-explosives-and-hme-precursors-detector> (accessed May 28, 2023)
- Yalçın, O., & Reyhancan, I. A. (2022). Detection of explosive materials in dual-energy X-Ray security systems. *Nuclear Instruments and Methods in Physics Research Section A: Accelerators, Spectrometers, Detectors and Associated Equipment*, 1040, 167265.
- Zhang, W., Tang, Y., Shi, A., Bao, L., Shen, Y., Shen, R., & Ye, Y. (2018). Recent developments in spectroscopic techniques for the detection of explosives. *Materials*, 11(8), 1364.



© 2024 by the authors; licensee Growing Science, Canada. This is an open access article distributed under the terms and conditions of the Creative Commons Attribution (CC-BY) license (<http://creativecommons.org/licenses/by/4.0/>).